

USER MANUAL



GT3 4K-25K

Copy Declaration

The copyright of this manual belongs to Hangzhou Livotek Power Co., Ltd. All rights reserved. Without the written permission of the company, Any unit or individual shall not extract or reproduce part or all of the contents of this document, and shall not transmit it in any form.

Table of Contents

1.	About This Manual.....	1
1.1	Scope.....	1
1.2	Intended Audience	1
1.3	Symbols Used	1
1.4	How to use this manual.....	1
2.	Safety	2
2.1	Product Description	2
2.2	Important Safety Instructions.....	2
2.3	Symbol on the Type Label.....	4
3.	Product Overview	5
3.1	View of the Inverter	5
3.2	Dimension	5
3.3	Terminal of the Inverter.....	6
3.4	System Dimension	7
4.	Scope of Delivery.....	8
5.	Mechanical Mounting	9
5.1	Requirements for Mounting	9
5.2	Mounting Instructions	12
6.	Electrical Connection	14
6.1	PV Connection	15
6.2	Grid Output Connection.....	18
6.3	Communication Connection.....	20
6.4	Earth Connection	22
6.5	Wi-Fi Connection	23
6.6	AFCI (optional).....	24
6.7	Installation Verification	26
7.	System Operation.....	27
7.1	Powering ON the Inverter.....	27
7.2	Powering OFF the Inverter.....	27
7.3	LEDs and Graphical Display.....	28
8.	Communication Mode Description.....	30
9.	Troubleshooting	32
10.	Technical Data.....	35
11.	Decommissioning.....	39
12.	Disclaimer.....	40
13.	Warranty Card Registration.....	41

1. About This Manual

1.1 Scope

This manual is valid for grid tied Inverter:



GT3-4KD1 GT3-5KD1 GT3-6KD1 GT3-8KD1 GT3-10KD1
GT3-12KD1 GT3-15KD1 GT3-17KD1 GT3-20KD1 GT3-22KD1
GT3-25KD1 GT3-10KDL1 GT3-12KDL1

1.2 Intended Audience

The manual is intended for photovoltaic (PV) inverter operating personnel and qualified electrical technicians. Any electrical installation and maintenance on this inverter must be performed by qualified electricians by professional electrical personnel who has obtained the license from local authorities.

1.3 Symbols Used

Safety instructions will be highlighted with the following symbols. These important instructions must be followed during installation, operation and maintenance of the inverter.

Symbol	Description
 DANGER	Indicates a hazard with a high level of risk that, if not avoided, will result in death or serious injury.
 WARNING	Indicates a hazard with a medium level of risk that, if not avoided, could result in death or serious injury.
 CAUTION	Indicates a hazard with a low level of risk that, if not avoided, could result in minor or moderate injury.
NOTICE	Indicates a situation that, if not avoided, could result in equipment or property damage.

1.4 How to use this manual

Read the manual and other related documents before performing any operation on the inverter. Documents must be stored carefully and be available at all times.

The information in this manual is subject to change without notice. Please check www.livoltek.com for more information.

2. Safety

2.1 Product Description

LIVOLTEK GT3 Series grid tied inverter, ideal for home, business and remote locations. The inverter generates renewable electricity from solar energy, and provides Pure Sine Wave AC output for connected equipment. Please read and follow all the instructions and cautions on the inverter and this user manual during installation, operation or maintenance at all times.

2.2 Important Safety Instructions

The safety instructions in this manual cannot cover all the precautions that should be followed. Perform operations considering actual onsite conditions. LIVOLTEK shall not be held liable for any damage caused by violation of the safety instructions in this manual.

2.2.1 Personnel Safety

- The inverter must be installed, electrically connected, operated and maintained by specially trained technician;
- The qualified technician must be familiar with the safety regulations of electrical system, working process of PV power generation system, and standards of local power grid;
- The technician must read through this User Manual carefully before any operations.

2.2.2 Inverter Protection

WARNING

Do not disconnect the PV connectors when the inverter is running. Ensure that there is no voltage or current before installing or disconnecting any connectors.

All safety instructions, warning labels, and nameplate on the inverter should not be removed or covered.

WARNING

When the photovoltaic array is exposed to light, it supplies a DC voltage to this equipment.

WARNING

Do not touch any hot parts (such as the heat sink) during operation.

CAUTION

Hot surfaces – To reduce the risk of burns – Do not touch.

"Do not remove cover until 5 minutes after disconnecting all sources of supply."















NOTICE

As soon as receiving the inverter please check if it is damaged during its transportation. If yes, please contact your dealer immediately.

Only qualified personnel can change the country settings.

- Adequate ventilation must be provided for inverter installation location
Mount the inverter in vertical direction, and ensure that no objects block the heat dissipation

2.3 Symbol on the Type Label

Symbol	Explanation
	CE mark. The inverter complies with the requirements of the applicable CE guild lines.
	UKCA mark. The inverter complies with the requirements of the applicable UKCA guidelines.
	UKNI mark. The inverter complies with the requirements of the applicable UKNI guidelines.
	Direct Current (DC)
	Alternating Current (AC)
	Point of connection for grounding protection
	RCM remark.
	SAA certification.
	Beware of hot surface. The inverter can become hot during operation. Avoid contact during operation.
	Danger of high voltages. Danger to life due to high voltages in the inverter!
	Danger. Risk of electric shock!
	Observe enclosed documentation.
	The inverter can not be disposed together with the household waste. Disposal information can be found in the enclosed documentation.
	Danger to life due to high voltage. There is residual voltage in the inverter which needs 5 min to discharge. • Wait 5 min before you open the upper lid or the DC lid.

3 Product Overview

3.1 View of the inverter

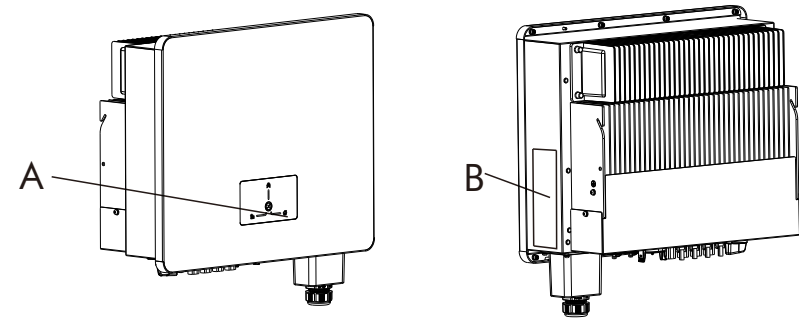

View the GT3 Series grid tied inverter

Position	Designation
A	LED indicator
B	Label

3.2 Dimension

GT3 4~25kW series of three-phase grid-tied inverter external dimensions.

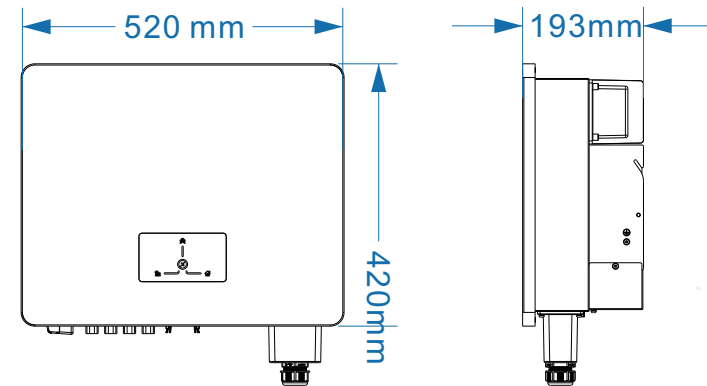

3.3 Terminals of the inverter

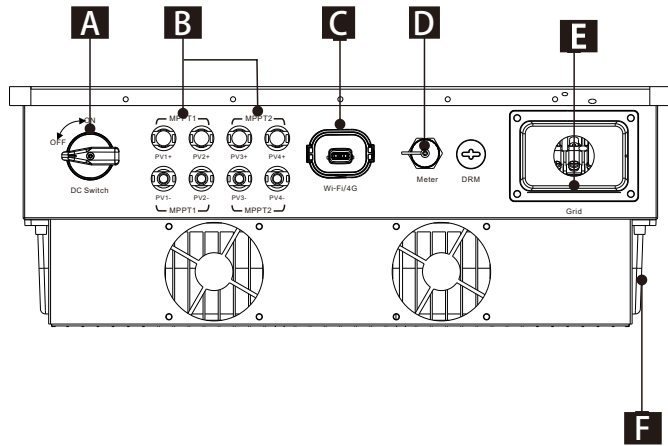

A	DC switch
B	PV connection area
C	Wi-Fi port
D	Meter communication port
E	Grid output port
F	Earth port

3.4 System Diagram

GT3 4-25kW series is a transformerless three-phase photovoltaic grid-tied inverter. As an indispensable part of the photovoltaic power generation system, the inverter mainly converts the direct current generated by the PV modules into alternating current that is compatible with the grid, and can feed the alternating current into the public grid.

A low-voltage grid-tied PV power system

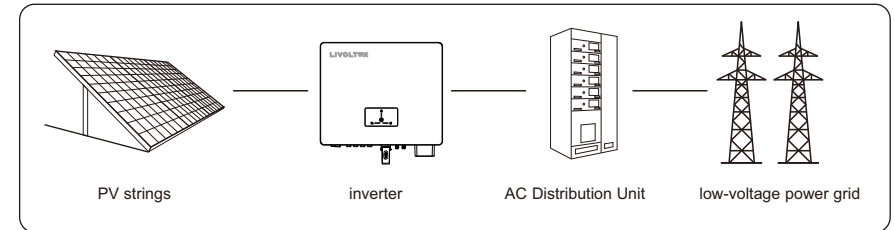

Note: This series of inverter are suitable for TN-S, TN-C, TN-C-S and TT power grid systems.

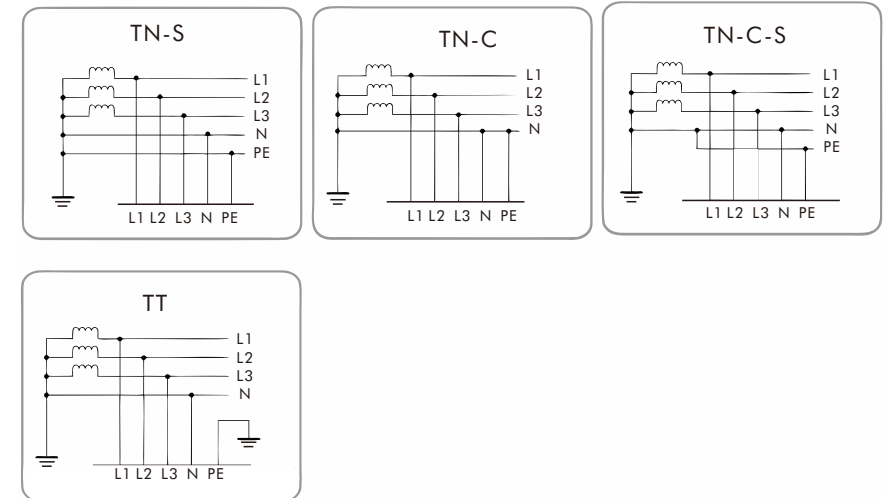

4 Scope of Delivery

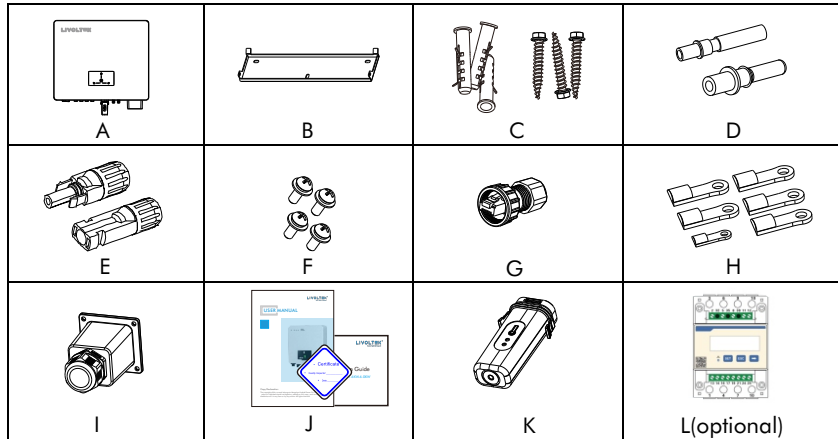

Item	QTY	Designation
A	1	Inverter
B	1	Bracket
C	3	Expansion screws for fixing mounting bracket
D	2/3/4	PV pin angle(positive*2/3/4 , negative*2/3/4)
E	2/3/4	PV terminal(positive*2/3/4 , negative*2/3/4)
F	4	M5 Screw for fixing the inverter
G	1	RJ45 terminal
H	6	O-shaped terminal (Includes 10WAG earth terminal)
I	1	Waterproof Cover
J	1	Certificate card /User manual /Quick installation guide
K	1	Wi-Fi
L	1	Smart Meter (optional)

5 Mechanical Mounting

5.1 Requirements for Mounting

NOTICE

- Make sure there is no electrical connection before installation.
- In order to avoid electric shock or other injury, make sure that holes will not be drilled over any electricity or plumbing installations.
- Always follow the instructions when moving and positioning the inverter.
- Improper operation may cause injuries or serious wounds. In the case of poor ventilation, the system performance may compromise.

5.1.1 Location Requirements

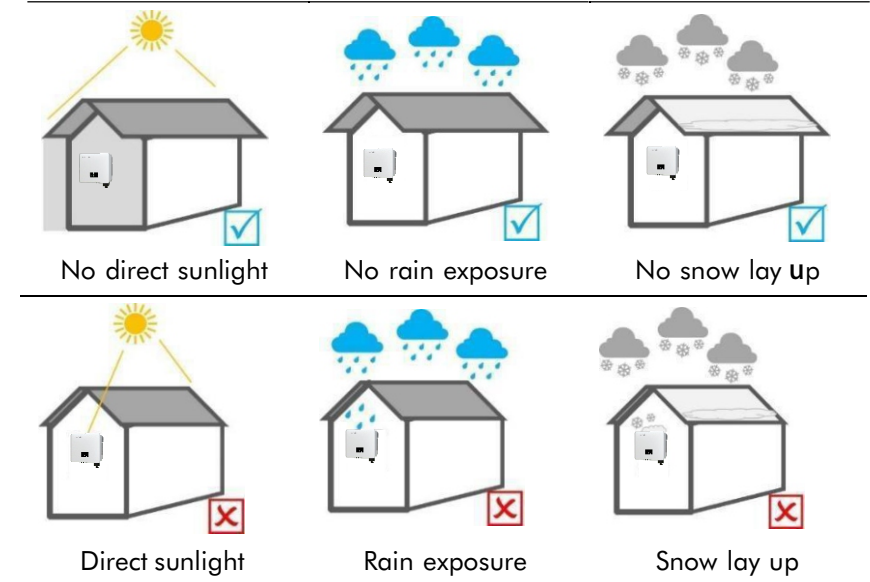

Select an optimal mounting location for safe operation, long service life and expected performance. During the installation and operation process, please the inverter in don't install the inverter where people may touch its casing and radiator, because these parts will be very hot during operation.

5.1.2 Environment Requirements

The inverter must be installed in a ventilated environment to ensure good heat dissipation. Make sure the installation site meets the following conditions:

- Not in areas where highly flammable materials are stored.
- Not in potential explosive areas.
- Not in the cool air directly.
- Not near the television antenna or antenna cable.
- Not higher than altitude of about 4000m above sea level.
- Not in environment of precipitation or humidity (>95%).
- Under good ventilation condition.
- The ambient temperature in the range of -30°C to +60°C.
- The slope of the wall should be within $\pm 5^\circ$.
- The wall hanging the inverter should meet conditions below:
- The wall must be solid enough to bear the weight of the inverter.
- Do not install the inverter on a wall made of gypsum boards or similar materials with weak sound insulation to avoid noise disturbance in a residential area.

5.1.3 Angle and Space Requirements

NOTICE

Never install the inverter horizontally, or with a forward tilt or with a backward tilt or even with upside down. The horizontal installation can result in damage to the inverter. Install the inverter upright or at a maximum back tilt of 15 degrees to facilitate heat dissipation.

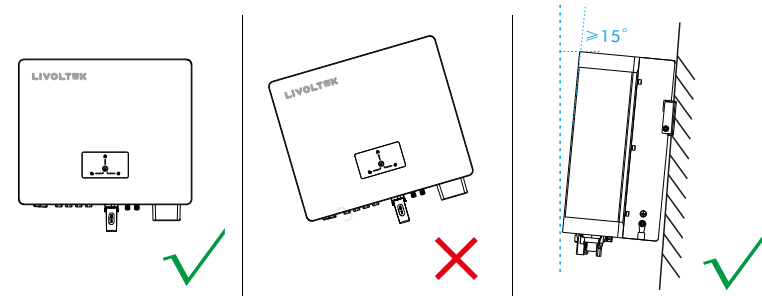

Reserve enough space when installing inverter (at least 300mm) for heat dissipation.

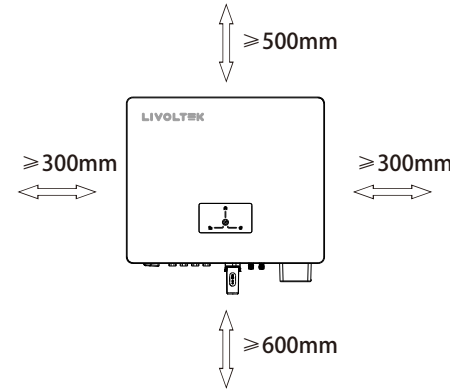

Reserved space dimensions of installation

Position	Min Distance
Left	300mm
Right	300mm
Up	500mm
Down	600mm
Forward	500mm

The distance of installation space for multiple inverter is as follows:

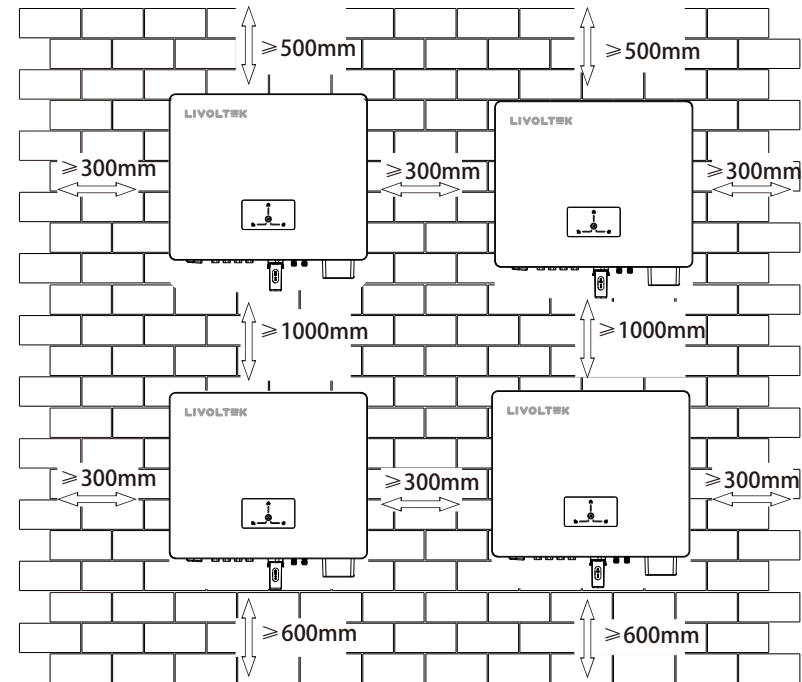

5.2 Mounting Instructions

Installation Tools (recommended but not limited to the following ones):
Protective glasses and gloves, Marker, Measuring tape, Multi-meter, Wire crimper, Stripping pliers, Screwdriver, Manual wrench, Hammer drill and drill bit, etc.

 Bit $\Phi 10$ Hammer drill	 Rubber hammer	 Tape ruler	 Spirit level\Marker
 Protective glasses	 Dustproof Cover	 OT terminals press clamp	 Wire stripper
 DC Voltage (Range $\geq 1100V$ DC) Multimeter	 Euro terminal crimping tool	 Diagonal pliers	 Multifunction terminal crimping tool (RJ45)

Mounting the Inverter

Step1: Drill holes on the wall

- Locate the appropriate drilling holes and mark it with a marker pen.
- Drill holes with driller, make sure the holes are deep enough (at least 50mm) to support the inverter.

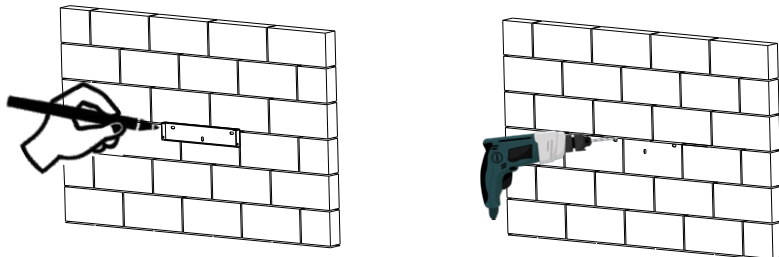

Step 2: Install the inverter to the wall

Insert the expansion tubes into the holes and hang the back plate, Then tighten the screws to install it.

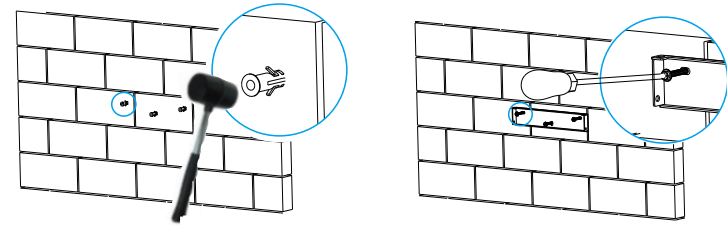

Step 3: Installation Self-check

Hang the inverter on the back panel and lock the side with screws.
(torque: $1.5N \cdot m$)

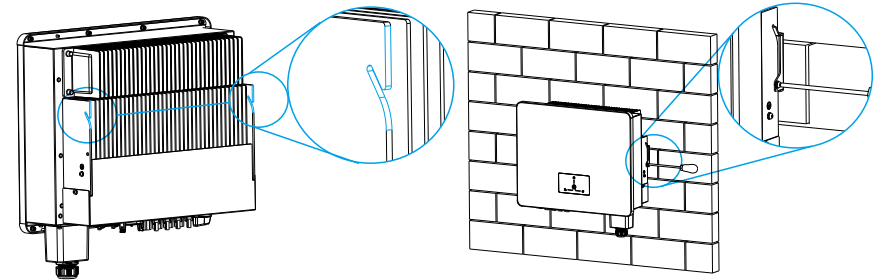

Step 4: Electrical Connection

Please refer to the operating instructions in the next chapter.

6 Electrical Connection

This chapter mainly describes the cable connections of the system. Prior to any electrical connections, keep in mind that the inverter has dual power supplies. It is mandatory for the qualified personnel to wear personal protective equipments (PPE) during the electrical work.

DANGER

Danger to life due to a high voltage inside the inverter!

- The PV string will generate lethal high voltage when exposed to sunlight.
- Before starting electrical connections, disconnect the DC and AC circuit breakers and prevent them from inadvertent reconnection.
- Ensure that all cables are voltage free before performing cable connection.

WARNING

- Any improper operations during cable connection can cause device damage or personal injury.
- Only qualified personnel can perform cable connection.
- All cables must be firmly attached, undamaged, properly insulated and adequately dimensioned.

NOTICE

- Comply with the safety instructions related to the PV strings and the regulations related to the utility grid.
- All electrical connections must be in accordance with local and national standards.

6.1 PV Connection

Please only use the PV connectors from the accessory box for connection. Before connecting, please make sure:

- The voltage, current and power ratings of the panels to be connected within the allowable range of the inverter. Ensure polarity is correct. Please refer to the Technical Data in chapter 9 for voltage and current limits.
- Since the inverter is transformerless, please do not ground either output of the PV panels. Ground the panel frames.
- Before connecting to PV modules, please install separately a DC circuit breaker between inverter and PV modules.
- To avoid any malfunction, do not connect any PV modules with possible current leakage to the inverter. For example, grounded PV modules will cause current leakage to the inverter. When using CIGS modules, please be sure NO grounding.
- If the inverter is equipped with a three-level lightning protection device, it's requested to use PV junction box with surge protection. Otherwise, it will cause damage on inverter when lightning occurs on PV modules.

Procedure

Model	Wire Size	Cable
4.0~25.0kW	12AWG	2.5-4.0mm ²

WARNING

- Use IEC61730 class-A Rating PV modules.
- When exposed to light, PV panels will generate DC voltage.
- Turn off the DC circuit breaker before connecting any wiring.
- All wiring must be performed by a qualified personnel.
- It's very important for system safe ty and efficient operation to use appropriate cable for PV module connection. To reduce risk of injury, please use the proper recommended cable size as below

⚠ WARNING

- This unit is not provided with a GFDI device. This inverter controller must be used with an external GFDI device as required by the article 690 of the National Electrical Code for the installation location.

Wiring Connection

Please follow below steps to implement PV module connection:

Step1: Remove an appropriate length of the insulation layer from the positive and negative power cables using a wire stripper.

Step2. Insert the exposed areas of the positive and negative power cables into the metal terminals of the positive and negative connectors respectively and crimp them using a crimping tool.

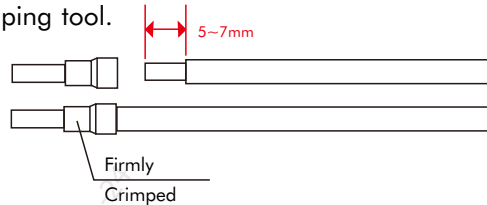

Step 3. Tighten the PV pin needle and the wiring harness to make the connection tight without looseness

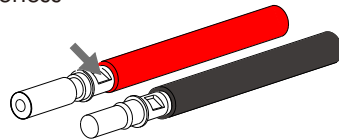

Step 4. The PV joint is divided into 2 parts - the plug and the fastening head. Insert the cable through the fastening head and the opposite plug. Note that the red and black lines correspond to different plugs. Finally, force the cable pair into the plug, will a "click" sound, which indicates that the connection is complete.

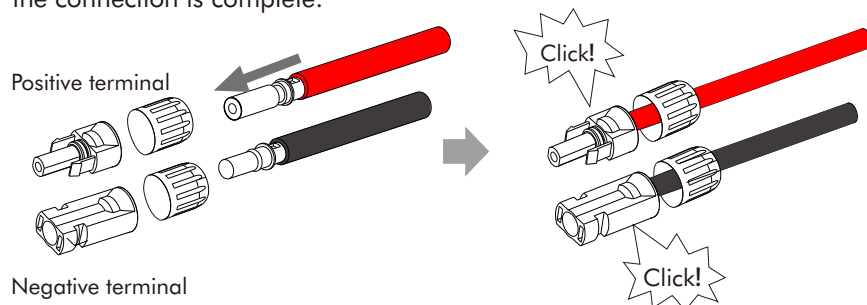

Step 5. Tighten the fastening head and into insert the corresponding positive and negative (PV-/PV+) ports of the inverter.

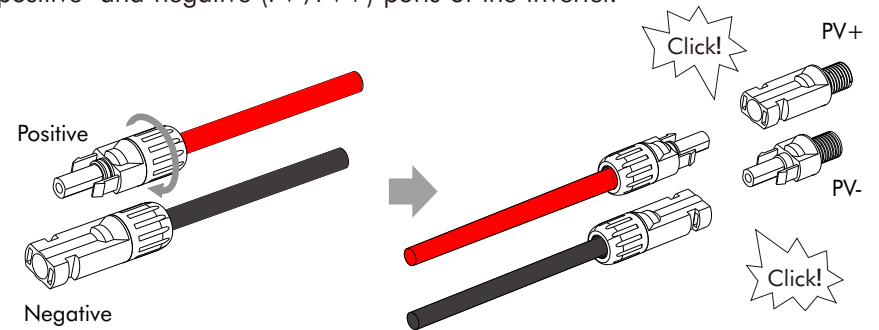

Step 6. Check correct polarity of wire connection from PV modules and PV input connectors. Then, connect positive pole (+) of connection wire to positive pole (+) of PV input connector. Connect negative pole (-) of connection wire to negative pole (-) of PV input connector.

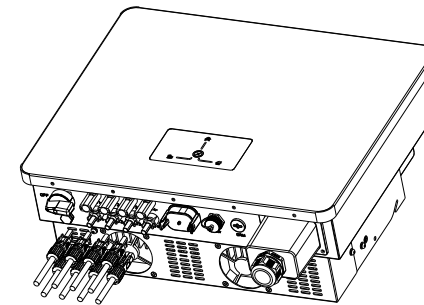

6.2 Grid Output Connection

⚠ WARNING

- The grid voltage and frequency must be in the permissible range.
- An external AC breaker must be installed between inverter and Grid input power source.
This will ensure the inverter can be securely disconnected during maintenance and fully protected from over current of Grid input.
- All wiring must be performed by a qualified personnel.
- Before making Grid input/output connection, be sure to open DC protector or disconnection first.
- Disconnect the circuit breaker and secure it against reconnection.

Take out the Grid connector parts from the packaging. And ensure the information below before connecting the inverter to the grid:

Suggested cable requirement for Grid wires

It's very important for system safety and efficient operation to use appropriate cable for Grid input connection. To reduce risk of injury, please use the proper recommended cable size as below.

Procedure:

Model	Wire Size	Cable	Breaker	Torque Valu (max)
GT3-4.0~10.0kW	8AWG	4-8mm ²	32A	1.5N • m
GT3-12.0~25.0kW	8AWG	4-8mm ²	60A	1.5N • m

GT3-4.0~25.0kW series Grid connection are as follows:

Step1: First pull out waterproof plug of the Grid Cover.

Step2: Puncture plug a, or drop plug a, And pass the Grid harness through the Grid cover.

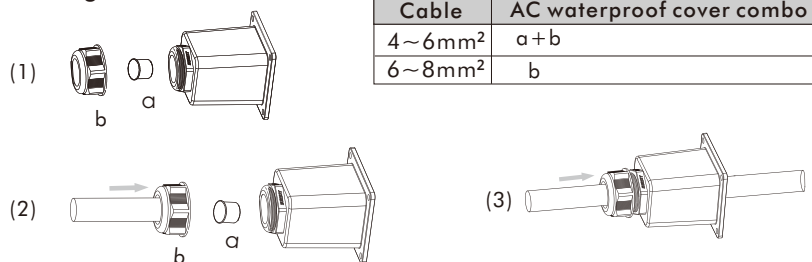

Step3: Remove the cable jacket and strip 70~80mm, And strip wire insulation by 7-10mm.

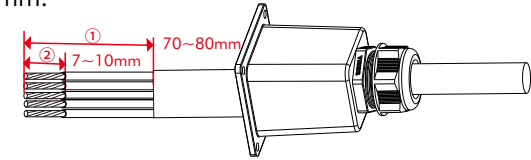

Step4: Insert the conductors to the corresponding terminal and crimp them. Pull cables outward to check whether they are firmly installed

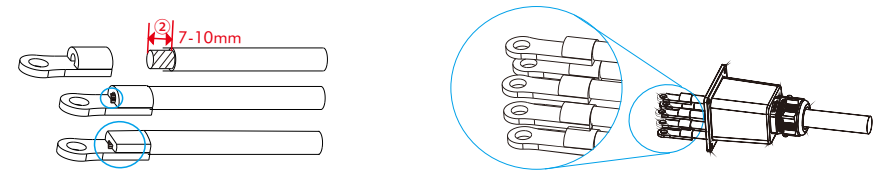

Step5: Tighten the L/N/PE screws of Grid respectively, and then fasten Grid Cover. (torque: 1.5N • m)

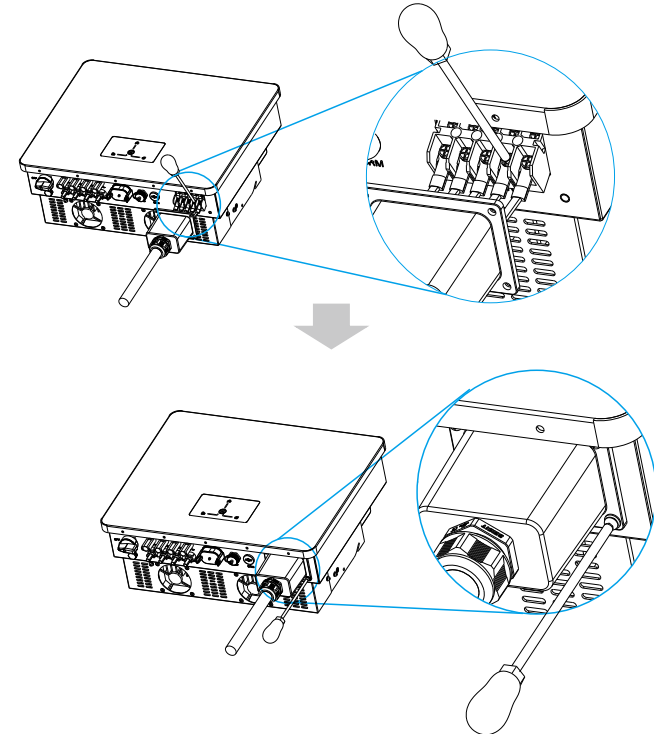

6.3 Communication Connection (Optional)

Meter Connection (Optional)

GT3 series three-phase grid-connected inverters should work with electric meter or current sensors to monitor household electricity consumption and limit the inverter's output power to the mains. In addition, the electricity meter can transmit the relevant electricity consumption data to the inverter or platform, which is convenient for users to read at any time.

Please note that the meter brand required by Livoltek must be used.

Meter connection diagram:

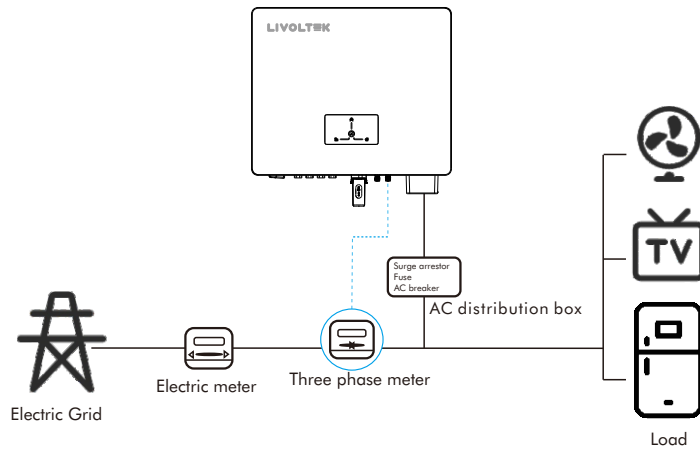

Communication connection

Step 1: Unscrew the cover, you see that is RJ45 ports.
(torque: 1.2N · m)

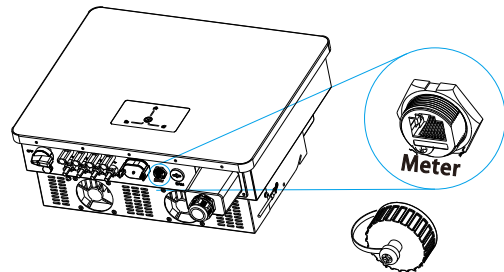

Step 2: Pass the wire harness through the cover with the waterproof plug, and then strip the wire. Stripping requirements: 5-7mm.

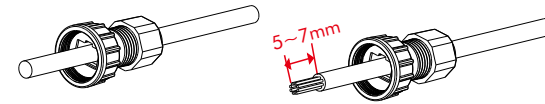

Step 3: Corresponding access according to the line sequence requirements of the RJ45 specification of the interface, and use a crimping tool to press it.

Meter Connector Pin Definition:

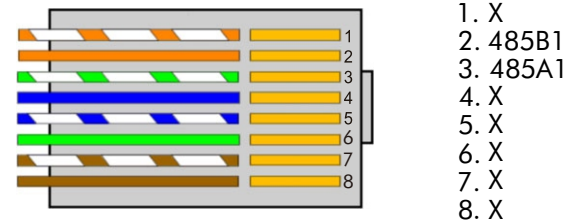

Step 4: GT3 series inverter support the connection of meter, and the PIN connected to meter is: 2/3.

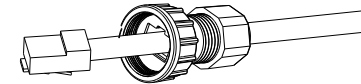

Step 5: Correspondingly insert the Meter port, and lock the cover.
(torque: 1.2N · m)

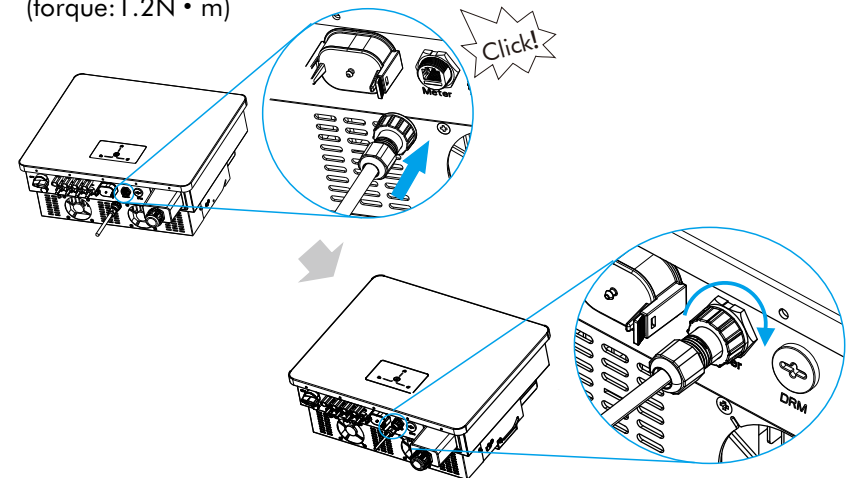

6.4 Earth connection(mandatory requirement)

⚠ WARNING

- Earth connection essential before connecting supply
- Be sure that AC power source is disconnected before attempting to hardwire it to the unit.

NOTICE

- Good grounding is good for resistance to surge voltage shocks and improves EMI performance. Therefore, before connecting AC, DC and communication cables, you need to ground the wires.
- For a Three inverter, simply ground the PE cable; For multi-inverter, the PE cables for all inverters need to be connected to the same grounded copper strip to ensure an equipotential connection.
- If the PV end of the inverter is not connected with earth, the inverter will turn on a red light inspect and report Earth Fault. This inverter complies with IEC 62109-1 clause 13.9 for earth fault alarm monitoring

Procedure:

Model	Wire Size	Cable	Torque Valu (max)
GT3-4.0~25.0kW	8AWG	2.5-4mm ²	1.5N • m

Step1: prepare a one-core wire, strip it 5-7mm and crimp the incoming Earth terminal ;

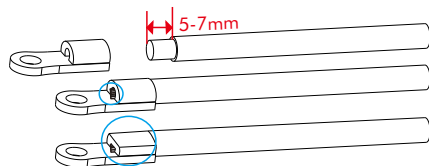

Step2: Then insert it through earth terminal and use a crimping tool to press it tightly ; (torque:1.5N • m)

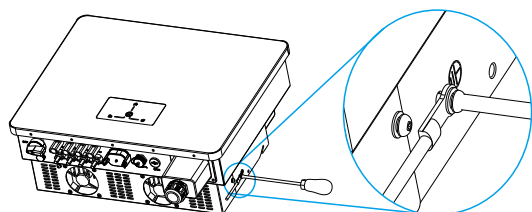

6.5 Wi-Fi Connection

The inverter provides a Monitoring module port, which can transmit data of the inverter to the monitoring website via Wi-Fi. (If necessary, purchase products from Livoltek)

Monitoring module connection diagram:

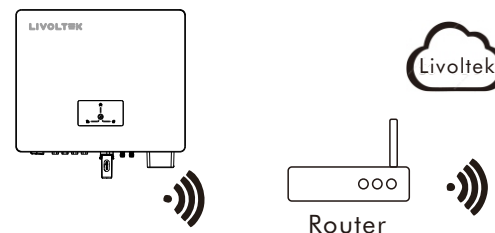

Wi-Fi module implements communication with Cloud server through wireless or Ethernet network to monitor inverter's data status. For more details, refer to Wi-Fi Product Application Manual.

Step 1: Disassemble Livoltek's Wi-Fi accessories, and open the waterproof plug of the Wi-Fi port on the inverter;

Step 2: Install the Wi-Fi module at the corresponding position in the inverter, and buckle tightly, you mainly need to hear a "click";

Please go to the Livoltek APP to connect to the Internet and set it up. For specific details, please refer to the Wi-Fi user manual.

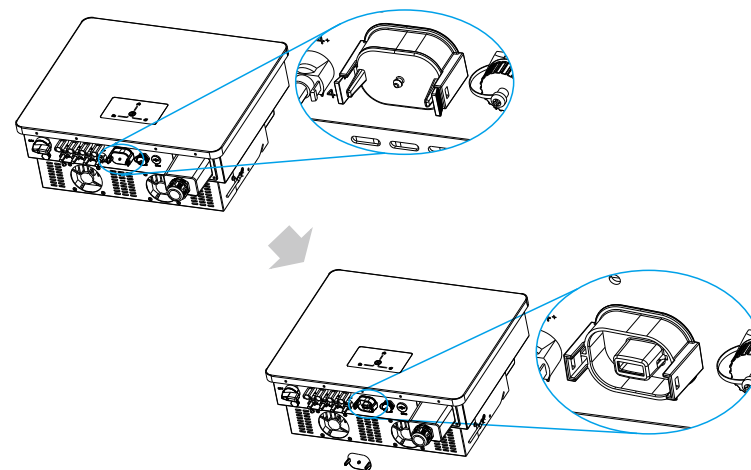

6.6 AFCI (Optional)

Arc-Fault Arc-Fault circuit interrupter (AFCI) refers to a photovoltaic module or cable that is not properly connected or damaged, and may produce an arc. According to UL 1699B:2018, the inverter has an arc detection and interrupt identification system, which produces an arc situation, and the inverter must trip within the specified time, and can only be manually reset to ensure the safety of the user's life and property. GT3 series inverter this function is turned on by default, if you do not need this function, you can log on to the Livoltek APP, cloud platform, local Bluetooth to turn off. (go to the "Advanced Settings" interface, select "AFCI function> Setting > Disable")

6.6.1 AFCI fault alarm cleared

Warning

- If an arc fault error occurs, follow the steps below to troubleshoot the AFCI fault and restart the inverter.
- Do not turn off AFCI permanently.

GT3 series has an automatic clearance mechanism for AFCI alarms. If an alarm is triggered less than 4 times in a 24-hour period and lasts less than 5 minutes, the inverter will automatically clear the alarm. If more than 5 consecutive alarms are triggered within 24 hours, the GT3 series inverter lock protection. Manual intervention is required to manually clear the alarm and restore the normal operation of the inverter.

When "AFCI Fault" is prompted, an arc has occurred in the PV system. The inverter will trip and shut down.

When "AFCI self-test fault" is prompted, an arc occurs in the PV system self-test. Inverter retest start.

How do I manually remove alarms?

Method 1: Livoltek App / Livoltek Cloud Platform / Local Bluetooth .

Log in to the Livoltek app /Livoltek cloud platform , the main menu enters the "Settings > Advanced Settings" interface, click "Restart".



Method 2: Put the DC and AC switches of the inverter in the "OFF" position. Wait for the screen to turn off.

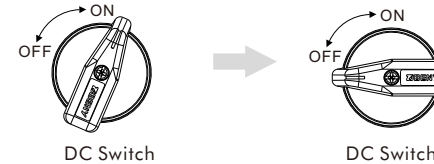

Check the wiring of the PV assembly, if there is a switch in the front stage of the PV, you need to check whether the switch wiring is abnormal. After troubleshooting, reboot the inverter and place the DC and AC switches in the "ON" position.

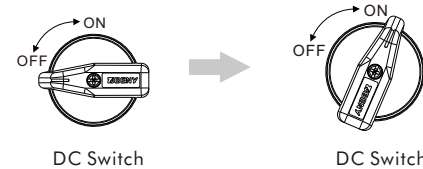

Remark

- If the system fault display is not eliminated, please contact customer service;
- After the circuit breaker or open and close between the inverter and the power grid, the inverter will start the countdown self-test, and the self-test will jump out "AFCI self-test..." After the self-test is normal, it can be connected to the power grid.

6.7 Installation Verification

Check the following items after the inverter is installed.

- No other objects put on the inverter.
- All screws especially the screws used for electrical connections are tightened.
- The inverter is installed correctly and securely.
- Ground, AC, DC and Communications cables are connected tightly correctly and securely.
- Check there is no open circuit or short circuits at AC and DC terminals using multi-meter.
- Idle terminals are sealed.
- All safety warning symbols are intact and complete on the inverter.

7 System Operation

7.1 Powering ON the Inverter

Step 1: Switch ON the DC and AC circuit breaker

Wait a few seconds and the inverter will start a self-test procedure when the indicator light flashes, when it is done successfully, the green led should be solid on and the graphical display should start displaying

Step 2: Switch on the loads

The load parameters should show. It is recommended to turn on one by one, to avoid triggering the protection action due to a large instantaneous impact when the load is turned on at the same time.



7.2 Powering OFF the Inverter

Step 1: Turn off the loads;

Step 2: Turn off the PV;

Step 3: Turn off the AC switch;

Step 4: Wait for at least 5 minutes after the LED and graphical display black out for the internal circuits to discharge energy;

Step 5: Disconnect all the power cables and communication cables if needed.

WARNING

After the inverter powers off the remaining electricity and heat may still cause electrical shock and body burns. Please only begin servicing the inverter ten minutes after the power-off.

7.3 LEDs and Graphical Display

The inverter operation status can be obtained from observing LED indicator status.

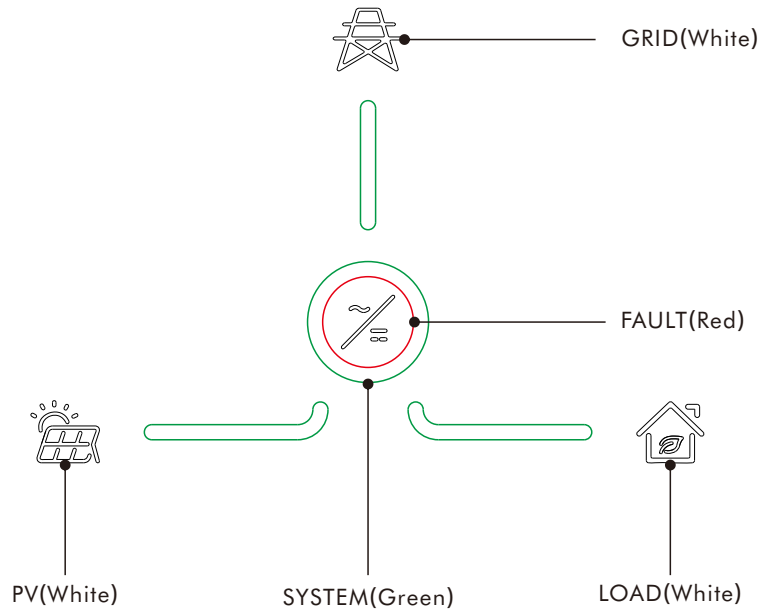

LED Indicator	Status	Description
Green	on	The inverter is running normally
	off	The inverter is not operating normally
	blink(System)	Updating
	blink(Load)	Standby
Red	on	Fault occurs
	off	No fault occurs
	blink	Fault occurs

Warning Definition	Warning Definition	LED Status
MPPT1 Over Volt	MPPT2 Over Current	Red blink(quickly)
MPPT1 Over Current	MPPT Over Current@HW	Red blink(quickly)
MPPT2 Over Volt	PV1 Port Over Current	Red blink(quickly)
PV2 Port Over Current	PV3 Port Over Current	Red blink(quickly)
PV4 Port Over Current	PV Insulation Abnormal	Red blink(quickly)
PV Reverse	DCI Abnormal	Red blink(quickly)
Grid volt. Sampling Fault	Grid Freq Abnormal	Red blink(Slowly)
Grid AC Volt Abnormal	Grid Freq Sampling Fault	Red blink(Slowly)
Grid Freq Abnormal	Grid Short Circuit	Red blink(Slowly)
BUS Over Volt (AC)	BUS Over Volt (AC)@HW	Red on
BUS Volt Unbalanced	AFCI Fault	Red on
INV Over Current	AFCI Self-test Fault	Red on
Fan Fault	Internal Comm. Fault	Red on
Leakage Current Abnormal	ATF Comm. Lost	Red on
Inter CKT Fault	Meter/CT Fault	Red on
AC Over Current @HD	AC Relay Fault	Red on
Inverter Over Temperature	EEPROM Fault	Red on
FW Incompatibility	FW Upgrading Failure	Red on
Ground Abnormal	Internal Comm. Fault(MCU1&2)	Red on
L/N Reversely Connected	Internal Comm. Fault(MCU1&3)	Red on
EEPROM Error	Internal Comm. Fault(MCU2&3)	Red on
RCD Self-test failure		Red on

8 Communication Mode Description

You can use the following communication modes to implement communication: Bluetooth and Wi-Fi, all of which are described as follows:

Wi-Fi & Bluetooth Module

The Wi-Fi with built-in Bluetooth module for local monitoring and managing. You can turn on the Bluetooth function of the mobile phone, and view & set data of the inverter through inverter APP.

Check www.livolttek-portal.com for details operation and APP User Manual, APP User Manual is available for free from website.

Download and Install Livolttek APP

- Method 1: Go to Google Play or Apple App Store to search Livolttek, download and install the app.
- Method 2: Scan QR code pasted on the right side of the inverter or below to download and install Livolttek app.

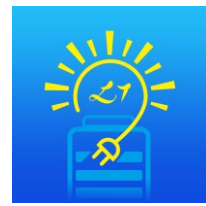

My Livolttek

Step 1: Open Livolttek APP, you can see the interface registration and local mode; (If You have registered, you can enter the account number and password to login)

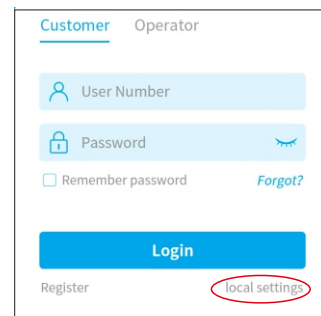

Step 2: Select Bluetooth, go in and choose to connect to the Bluetooth of the corresponding model, and see the system running status is successful; (inverter Bluetooth is composed of the series and the last six digits of SN);

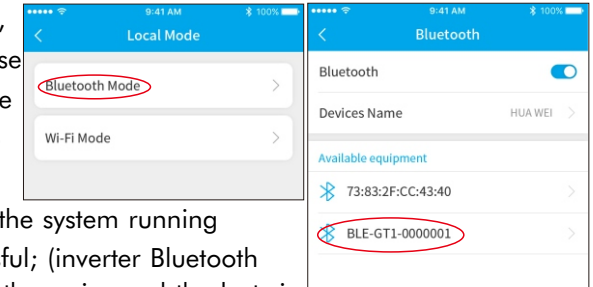

Step 3: Click "Settings" to enter "Basic settings" you can set the date time, language, and view view the inverter model, inverter version and inverter serial number.

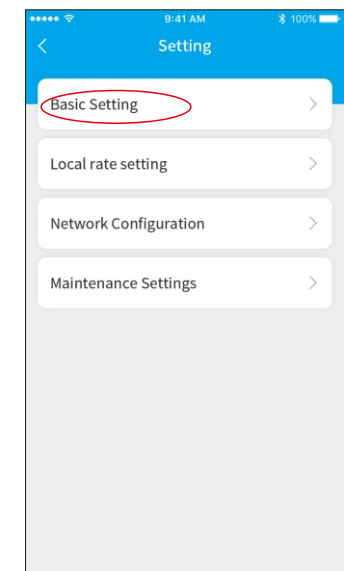
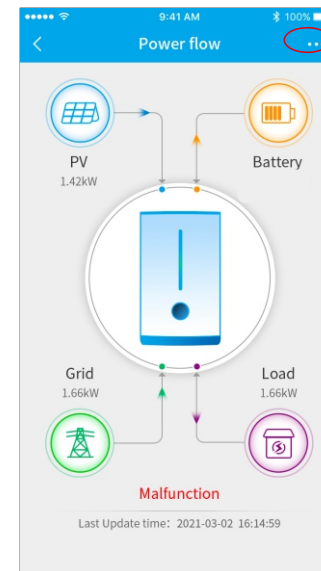

9 Troubleshooting

Error Message	Measures Recommended
MPPT1 Over Volt	1. Check if voltage and number of PV strings are meet requirements and adjust it if need. 2. Wait a moment for inverter recovery or restart the system.
MPPT1 Over Current	1. Check the PV input power and configuration. 2. Wait a moment for inverter recovery or restart the system.
MPPT2 Over Volt	1. Check if voltage and number of PV strings are meet requirements and adjust it if need. 2. Wait a moment for inverter recovery or restart the system.
MPPT2 Over Current	1. Check the PV input power and configuration. 2. Wait a moment for inverter recovery or restart the system.
MPPT Over Current@HW	1. Check the PV input power and configuration. 2. Wait a moment for inverter recovery or restart the system.
Grid AC Volt Abnormal	1. If the alarm occurs accidentally, possibly the power grid is abnormal accidentally. No extra action is needed. 2. If the alarm occurs repeatedly: a. make sure the grid standards is set right and contact the local power station. After receiving approval of the local power bureau, revise the electrical protection parameters setting on inverter through Local Mode of Livoltek APP. b. make sure the AC cable is connected well and the jacket of the AC cable is not compressed into the AC terminal. c. make sure if the grid has power outage frequently.
Grid Freq Abnormal	
BUS Over Volt (AC)	
BUS Volt Unbalanced	1. Wait a moment for inverter recovery or restart the system. 2. If the alarm occurs repeatedly, contact your dealer for technical support.
INV Over Current	
DCI Abnormal	
Leakage Current Abnormal	1. Check if the EPS output wires are well connected. 2. Restart the inverter, if the error happens again, contact your dealer for technical support.
AC Over Current @HD	1. If the alarm occurs occasionally, the inverter can automatically recover to the normal operating status after the fault is rectified
Inverter Over Temperature	2. If the alarm occurs repeatedly, contact your dealer technical support.
Ground Abnormal	1. Check whether there is a reliable grounding connection. 2. Check whether the L-line and N-line are connected correctly.
L/N Reversely Connected	3. If there is correctly wired, but the alarm still exists, please contact your dealer for technical support.

PV Insulation Abnormal	1. If the alarm occurs occasionally, the inverter can automatically recover to the normal operating status after the fault is rectified 2. If the alarm occurs repeatedly, contact your dealer technical support.
RCD Self-test Failure	
AC Relay Fault	
EEPROM Error	1. If the alarm occurs occasionally, the inverter can automatically recover to the normal operating status after the fault is rectified 2. If the alarm occurs repeatedly, contact your dealer technical support
Grid Volt. Sampling Fault	
Internal Comm. Fault(MCU1&2)	1. If the alarm occurs occasionally, the inverter can automatically recover to the normal operating status after the fault is rectified 2. If the alarm occurs repeatedly, contact your dealer technical support
Internal Comm. Fault(MCU1&3)	
Internal comm. Fault(MCU2&3)	
PV Reverse	Disconnected the DC switch, check whether the cables of PV strings are correctly connected, if not, reconnect the cables.
FW Incompatibility	Please contact your dealer for technical support.
Fan Fault	1. If the alarm occurs occasionally, the inverter can automatically recover to the normal operating status after the fault is rectified 2. If the alarm occurs repeatedly, contact your dealer technical support
Grid Freq Sampling Fault	Please contact your dealer for technical support.
Grid Short Circuit	1. Check whether the grid lines are connected correctly. 2. If there is correctly wired, but the alarm still exists, please contact your dealer for technical support.
Inter CKT Fault	1. If the alarm occurs occasionally, the inverter can automatically recover to the normal operating status after the fault is rectified 2. If the alarm occurs repeatedly, contact your dealer technical support.
PV1 Port Over Current	1. Check the PV input power and configuration. 2. Wait a moment for inverter recovery or restart the system.
PV2 Port Over Current	
PV3 Port Over Current	
PV4 Port Over Current	
BUS Over Volt (AC)@HW	1. Wait a moment for inverter recovery or restart the system. 2. If the alarm occurs repeatedly, contact your dealer for technical support.

AFCI Fault	<ol style="list-style-type: none"> 1. Turn off the PV system and check whether there is a DC arcing fault on the PV side. 2. Try to restart the inverter, check if it still occurs. If not, it is just an occasional situation. 3. If the alarm occurs repeatedly or lasts a long time, please contact your dealer for technical support.
AFCI Self -test Fault	<ol style="list-style-type: none"> 1. Try to restart the inverter, check if it still occurs. If not, it is just an occasional situation. 2. If the alarm occurs repeatedly or lasts a long time, please contact your dealer for technical support.
Internal Comm. Fault	<ol style="list-style-type: none"> 1. If the alarm occurs occasionally, the inverter can automatically recover to the normal operating status after the fault is rectified 2. If the alarm occurs repeatedly, contact your dealer technical support.
ATF Comm. Lost	<ol style="list-style-type: none"> 1. Check whether the communication cable between the module and the inverter is properly connected. 2. If the alarm occurs repeatedly or lasts a long time, please contact your dealer for technical support.
Meter/CT Fault	<ol style="list-style-type: none"> 1. Check whether the communication cable between the meter/CT and the inverter is properly connected. 2. If the alarm occurs repeatedly or lasts a long time, please contact your dealer for technical support.
Internal Comm. Fault	<ol style="list-style-type: none"> 1. If the alarm occurs occasionally or only in the morning, and the inverter can automatically recover to normal (including restart at next day), no action is required. 2. If the alarm occurs repeatedly, contact your dealer for technical support.
EEPROM Fault	Contact your dealer to replace the monitoring board.
FW Upgrading Failure	Contact your dealer to upgrade its firmware

10 Technical Data

Technical Data	GT3-4KD1	GT3-5KD1	GT3-6KD1	GT3-8KD1	GT3-10KD1	GT3-12KD1	GT3-15KD1
PV Input Data							
Max. DC Input Power [Wp]	6000	7500	9000	12000	15000	18000	22500
Max. DC Input Voltage[V]	1100						
Min PV input voltage[V]	140						
Start-up DC Input Voltage[V]	160						
Nominal DC Input Voltage[V]	650						
MPPT Operating Range[V]	140-1000						
MPPT Operating Range(Full-Load)[V]	140-850	176-850	200-850	281-850	350-850	225-850	281-850
Max. DC Input Current[A]	16/16	16/16	16/16	16/16	16/16	40/20	40/20
Max. Short Circuit current[A]	21/21	21/21	21/21	21/21	21/21	52/26	52/26
No. of MPPTs	2						
No. of Strings per MPP Trackers	1/1	1/1	1/1	1/1	1/1	2/1	2/1
AC Output Data							
Nominal Output Power [W]	4000	5000	6000	8000	10000	12000	15000
Max. Apparent Power [VA]	4400	5500	6600	8800	11000	13200	16500
Rated AC Grid Output Current[A]	5.8	7.2	8.7	11.5	14.4	17.3	21.7
Max. AC Output Current[A]	6.4	7.9	9.5	12.7	15.9	19.1	23.8
Rated AC Grid Voltage[V]	3/N/PE,220/380,230/400						
AC Grid Voltage Range①[V]	270-480						
Rated Grid Frequency [Hz]	50/60						
Grid Frequency Range②[Hz]	45-55/55-65						
Power Factor	> 0.99 Rated power (Adjustable 0.8 Leading - 0.8Lagging)						
Output THDi (@Nominal Output)	<3%						
Efficiency							
Max. Efficiency[%]	98.5	98.5	98.6	98.6	98.6	98.5	98.5
Euro Efficiency[%]	98.1	98.1	98.2	98.2	98.2	98.1	98.1
MPPT Efficiency[%]	>99						
Protection							
Integrated DC Switch	Optional						
DC Reverse Polarity Protection	Support						
DC SPD Protection	Type II						
PV Current Detection	Support						
Insulation Resistor Detection	Support						

Output Over Current Protection	Support
AC Short Circuit Protection	Support
Output Over Voltage Protection	Support
AC SPD Protection	Type II
Anti -islanding Protection	Support
Temperature Protection	Support
Ground Fault Monitoring	Support
Internal Over Voltage Protection	Support
Input Over Current Protection	Support
Grid Monitoring	Support
Residual Current Monitoring Unit	Support
AFCI Protection	support (optional)
General Data	
Dimensions[W*H*D] [mm]	520*420*193
Weight [kg]	22 24.5
Mounting Information	Wall Mounting
Protection Degree	IP65
Cooling	Natural cooling Fan
Operating Temperature Range [°C]	- 30 ... +60 (derating at 45°C)
Relative Humidity	0- 100%
Max. Operating Altitude(mm)	4000 (≥3000 derating)
Typical Noise Emission(dB)	< 30
Night Self Consumption [W]	< 1
Display	LED+APP
Communication	RS485 (Meter),4G/Wi - Fi+Bluetooth
Topology	Transformerless
Certifications and Standards	
Grid Regulation	IEC61727, IEC62116,CQC ABNT NBR 16149, ABNT NBR 16150
Safety	IEC62109- 1/2
EMC	EN61000 -6-1/2/3/4
Standard Warranty[years]	5 Years (10 years optional)

Technical Data	GT3-17KD1	GT3-20KD1	GT3-22KD1	GT3-25KD1	GT3-10KDL1	GT3-12KDL1
PV Input Data						
Max. DC Input Power [Wp]	25500	30000	33000	37500	15000	18000
Max. DC Input Voltage[V]	1100			1100		
Min PV input voltage[V]	140			140		
Start -up DC Input Voltage[V]	160			160		
Nominal DC Input Voltage[V]	650			650		
MPPT Operating Range[V]	140-1000			140-600		
MPPT Operating Range(Full-Load)[V]	239-850	280-850	280-850	350-850	187-850	225-850
Max. DC Input Current[A]	40/40	40/40	40/40	40/40	40/40	40/40
Max. Short Circuit current[A]	52/52	52/52	52/52	52/52	52/52	52/52
No. of MPPTs	2			2	2	
No. of Strings per MPP Trackers	2/2	2/2	2/2	2/2	2/2	2/2
AC Output Data						
Nominal Output Power [W]	17000	20000	22000	25000	10000	12000
Max. Apparent Power [VA]	18700	22000	24200	27500	11000	13200
Rated AC Grid Output Current[A]	24.5	28.9	31.8	36.1	26.2	31.5
Max. AC Output Current[A]	27.0	31.8	34.9	39.7	28.9	34.6
Rated AC Grid Voltage[V]	3/N/PE,220/380,230/400			3/N/PE,127/220		
AC Grid Voltage Range①[V]	270-480			127-300		
Rated Grid Frequency [Hz]	50/60			50/60		
Grid Frequency Range②[Hz]	45 -55/55-65					
Power Factor	> 0.99 Rated power (Adjustable 0.8 Leading - 0.8Lagging)					
Output THDi (@Nominal Output)	<3%					
Efficiency						
Max. Efficiency[%]	98.5	98.6	98.6	98.6	98.6	98.6
Euro Efficiency[%]	98.1	98.2	98.2	98.2	98.2	98.2
MPPT Efficiency[%]	>99			>99		
Protection						
Integrated DC Switch	Optional					
DC Reverse Polarity Protection	Support					

DC SPD Protection	Type II
PV Current Detection	Support
Insulation Resistor Detection	Support
Output Over Current Protection	Support
AC Short Circuit Protection	Support
Output Over Voltage Protection	Support
AC SPD Protection	Type II
Anti -islanding Protection	Support
Temperature Protection	Support
Ground Fault Monitoring	Support
Internal Over Voltage Protection	Support
Input Over Current Protection	Support
Grid Monitoring	Support
Residual Current Monitoring Unit	Support
AFCI Protection	Support (optional)
General Data	
Dimensions[W*H*D] [mm]	520*420*193
Weight [kg]	24.5
Mounting Information	Wall Mounting
Protection Degree	IP65
Cooling	Fan cooling
Operating Temperature Range [°C]	- 30 ... +60 (derating at 45°C)
Relative Humidity	0-100%
Max. Operating Altitude(mm)	4000 (≥3000 derating)
Typical Noise Emission(dB)	<40
Night Self Consumption [W]	<1
Display	LED+APP
Communication	RS485 (Meter) ,4G/WiFi+Bluetooth
Topology	Transformerless
Certifications and Standards	
Grid Regulation	IEC61727, IEC62116,CQC, ABNT NBR 16149, ABNT NBR 16150
Safety	IEC62109-1/2
EMC	EN61000-6-1/2/3/4
Standard Warranty[years]	5 Years (10 years optional)

11 Decommissioning

11.1 Disassemble the Inverter

- Remove DC input line and AC output line of inverter.
- Wait for at least 5 minutes to power off.
- Remove all cable connections from the inverter.
- Remove inverter from finger support the bracket.
- Remove the bracket if necessary.
- Load the inverter into the original package if possible.

11.2 Packing

- Load the inverter into the original package if possible.
- If the original package can not be found, you can also use the following requirements of the carton packaging:
- Bearing capacity of more than 30 kg.
- Easy to carry.
- Can completely seal the cover.

11.3 Storage and Transportation

- Store the inverter in a dry, temperature -40°C~70°C environment.
- Pay attention to less than four machines on each stack board during storage and transportation.

11.4 Waste Disposal

- If it is necessary to scrap the inverter or other related parts, be sure to send the waste inverter and packaging materials to the designated location for recycling by the relevant department.

12 Disclaimer

The GT3 series inverters are transported, used and operated under limited condition, such as environmental, electrical etc. Livoltek shall not be liable to provide the service, technical support or compensation under conditions listed below, including but not limited to:

- . Inverter is damaged or broken by force majeure (such as earthquake, flooding, thunderstorm, lightning, fire hazard, volcanic eruption etc.).
- . Inverter's warranty is expired and doesn't buy extended warranty.
- . Can't provide the inverter's SN, warranty card or invoice.
- . Inverter is damaged by man-made cause.
- . Inverter is used or operated against any items in local policy.
- . Inverter's installation, configuration, commissioning doesn't follow the requirements mentioned in this manual.
- . Inverter is installed, refitted or operated in improper ways mentioned in this manual without authority from Livoltek.
- . Inverter is installed, operated under improper environment or electrical condition mentioned in this manual without authority from Livoltek.
- . Inverter is changed, updated or disassembled on hardware or software without authority from Livoltek.
- . Obtain the communication protocol from other illegal channels.
- . Build monitoring, control system without authority from Livoltek.
- . Livoltek will keep right to explain all the contents in this user manual.

Warranty Card Registration

LIVOLTEK

Dear customer, thank you for choosing LIVOLTEK product. For registering product warranty, please prepare everything ready and register on

<https://livoltek.com/service/warranty/#warranty-activation>.

Product Information	
Product Type	
Product S/N	
Installation date	
Installation Company	
Personal Information	
Your name	
Your contact number	
Your Email address	
Your home address	

*Warranties should be registered within 36 months of installation, however it is recommended that they are registered no more than 6 weeks following the successful installation and commissioning of the Product where possible, thanks for your cooperation.

