

USER MANUAL



HP3-5-12KD2
HP3-5-6KL2

Copyright Declaration

The copyright of this manual belongs to Hangzhou Livoltek Power Co.,Ltd.. Any corporation or individual should not plagiarize, partially or fully copy and no reproduction or distribution of it in any form or by any means. All rights reserved.

Contents

1	About This Manual	1
1.1	Scope of Validity.....	1
1.2	Target Group	1
1.3	Symbol Definition.....	1
2	Safety Precaution	2
2.1	Personnel Requirements.....	2
2.2	Inverter Safety.....	2
2.3	Battery Safety.....	3
2.4	Installation Safety	3
2.5	Electrical Safety	3
2.6	Maintenance and Replacement.....	4
2.7	PE Connection and Leakage Current	4
2.8	EU Declaration of Conformity.....	5
3	Product Introduction.....	6
3.1	Product Description.....	6
3.2	Application Scenarios.....	6
3.3	Power Derating.....	7
3.4	Declaration for Back-Up Function.....	7
3.5	System Architecture.....	8
3.6	Appearance and Dimension	9
3.7	Terminal Description	10
3.8	Work Modes	11
3.8.1	On-Grid Self-Use Mode.....	12
3.8.2	On-Grid ToU Mode	12
3.8.3	On-Grid Backup Mode.....	13
3.8.4	Off-Grid Mode.....	13
4	Unpacking and Storage.....	14
4.1	Packing List	14
4.2	Identification Label.....	16
4.2.1	Nameplate	16
4.2.2	Compliance and Safety Symbols	17
4.3	Storage of Inverter	18
5	Installation.....	19
5.1	Installation Requirements.....	19
5.1.1	Location Requirements.....	19
5.1.2	Environment Requirements.....	20
5.1.3	Angle and Space Requirements.....	20
5.1.4	Tools Preparation.....	21
5.2	Mounting Instruction	21

5.2.1 Mounting the Inverter.....	21
6 Electrical Connection	23
6.1 Wiring Diagram	24
6.2 External Grounding (PE Cable) Connection.....	25
6.2.1 External Grounding Requirements.....	25
6.2.2 Wiring Connection Procedure	25
6.3 Grid Port Connection.....	26
6.3.1 Wiring Connection Procedure	26
6.3.2 Residual Current Monitoring Device	27
6.4 EPS Output Connection.....	28
6.5 PV Connection.....	28
6.6 Battery Connection.....	31
6.6.1 Battery Connection.....	32
6.6.2 BMS Cable Connection.....	34
6.7 WIFI Connection	35
6.8 DRM Connection.....	36
6.9 MULTI COM Terminal Connection.....	37
6.9.1 MULTI COM Terminal Pin.....	37
6.9.2 16pin terminals.....	38
6.9.3 EV charger Connection.....	38
6.9.4 Diesel Generator Connection.....	39
6.9.5 Installation Verification.....	41
6.10 Smart Meter Connection.....	42
6.11 PAL Connection	43
7 System Operation.....	44
7.1 LED Display.....	44
7.2 Start-up Procedures.....	45
7.3 Shut down Procedures	46
8 APP Operation.....	47
8.1 Download, Configuration, Registration and Login	47
8.1.1 Downloading and Installing.....	47
8.1.2 Configuration.....	48
8.1.3 Registration, Site Creation and Device Adding	52
8.2 Function Setting.....	57
9 Troubleshooting and Maintenance.....	58
9.1 Troubleshooting.....	58
9.2 Routine Maintenance.....	61
9.3 Decommissioning.....	61
9.4 Disposal of the Inverter	61
10 Technical Data.....	62
11 Disclaimer.....	68

1 About This Manual

Thank you for choosing our three-phase high-voltage hybrid inverter. This manual will assist you in becoming familiar with this product. Please keep this manual available at any time. And read the manual and other related documents before performing any operation on the inverter and consider the connection requirements by your local grid utility. This manual cannot include complete information about the photovoltaic (PV) system. All descriptions in the manual are for guidance only.

1.1 Scope of Validity

This manual describes the installation process, maintenance, technical data and safety instructions for the following models:

HP3-5KD2, HP3-6KD2, HP3-8KD2, HP3-9.9KD2, HP3-10KD2, HP3-12KD2
HP3-5KL2, HP3-6KL2





“HP3” means three-phase Hybrid Series inverter.

“5K” means the rated power is 5000W.

1.2 Target Group

This manual is intended for qualified persons and inverter owners. All activities described in the document may only be carried out by specially trained personnel in compliance with standards, wiring rules and the requirements of local grid authorities or companies. Moreover, they must also understand basic safety precautions and with the knowledge of how to deal with the dangers and risks associated with installing, repairing and using electrical devices and batteries.

1.3 Symbol Definition

Symbol	Description
 DANGER	Indicates a hazard with a high level of risk that, if not avoided, will result in death or serious injury.
 WARNING	Indicates a hazard with a medium level of risk that, if not avoided, could result in death or serious injury.
 CAUTION	Indicates a hazard with a low level of risk that, if not avoided, could result in minor or moderate injury.
 NOTICE	Indicates a situation that, if not avoided, could result in equipment or property damage.

Note: This user manual is subject to change (specific please in kind prevail) without prior notice. For more product details and latest documents, visit <https://livotek.com>.



2 Safety Precaution

- The inverter has been designed and tested strictly in accordance with international safety regulations. As with all electronic equipment, there are residual risks despite careful construction.
- Read all safety instructions carefully prior to any work and observe them at all times when working on or with the inverter to prevent personal injury and property damage and to ensure long-term operation of the inverter.
- Ensure that the equipment is used in environments that meet its design specifications. Otherwise, the equipment may become faulty, and the resulting equipment malfunction, component damage, personal injuries, or property damage are not covered under the warranty.
- Follow local laws and regulations when installing, operating, or maintaining the equipment. The safety instructions in this document are only supplements to local laws and regulations.



2.1 Personnel Requirements

- The inverter must be installed, electrically connected, operated and maintained by specially trained and qualified electrician.
- The qualified persons who plan to install or maintain LIVOLTEK equipment must receive thorough training, understand all necessary safety precautions, and be able to correctly perform all operations.

2.2 Inverter Safety

 DANGER
Danger to life due to electric shock when live components are touched on opening the product. <ul style="list-style-type: none">• High voltages are present in the live parts and cables inside the product during operation. Touching live parts and cables results in death or lethal injuries due to electric shock.• Do not open the inverter cover or change any components without manufacturer's authorization. Otherwise, the warranty for the inverter will be invalid.
 WARNING
Danger to life due to fire or explosion. <ul style="list-style-type: none">• In rare cases, an explosive gas mixture can be generated inside the product under fault conditions. In this state, switching operations can cause a fire inside the product or explosion. Death or lethal injuries due to hot or flying debris can result.• In the event of a fault, do not perform any direct actions on the product.• Ensure that unauthorized persons have no access to the product.• Only perform work on the product when wearing personal protective equipment for handling of hazardous substances.• Wait at least 5 minutes for the internal capacitors to discharge after the battery is powered off.• Ensure that there is no voltage or current before installing or disconnecting any connectors.• All safety instructions, warning labels, and nameplate on the inverter should not be removed or covered.
 CAUTION
Risk of burns due to hot components! Avoid any unnecessary touching! <ul style="list-style-type: none">• Do not touch any hot parts (such as the heat sink) during operation. Only the DC switch can safely be touched at any time.

2.3 Battery Safety

 DANGER
<p>Danger to life from electric shock due to live DC cables at the battery. The DC cables connected to a battery may be live. Touching the DC conductors or the live components leads to lethal electric shocks.</p> <ul style="list-style-type: none">• Do not touch non-insulated cable ends.• Do not touch any live components.• Observe all safety information of the battery manufacturer.• Prior to performing any work on the inverter or the battery, disconnect the inverter from all voltage sources as described in this document.• If an error occurs, have it rectified by qualified persons only.
 WARNING
<p>Risk of burns due to electric arcs.</p> <ul style="list-style-type: none">• Short-circuit currents in the battery can cause heat build-up and electric arcs.• Disconnect the battery from all voltages sources prior to performing any work on the battery.

2.4 Installation Safety

NOTICE
<ul style="list-style-type: none">• As soon as receiving the inverter please check if it is damaged during its transportation. If yes, please contact your dealer immediately.• Adequate ventilation must be provided for inverter installation location.• Mount the inverter in vertical direction, and ensure that no objects block the heat dissipation.• The safety instructions in this manual cannot cover all the precautions that should be followed. Perform operations considering actual onsite conditions.• LIVOLTEK shall not be held liable for any damage caused by violation of the safety instructions in this manual.

2.5 Electrical Safety

 DANGER
<ul style="list-style-type: none">• Before installing the inverter check all electrical ports to ensure no damage and no short circuit, otherwise personal casualty and or fire will occur.• Install the external protective grounding cable first when performing electrical connection and remove the external protective grounding cable last when removing the inverter.• Check the positive and negative polarity of the PV strings, and connect the PV connectors to corresponding terminals only after ensuring polarity correctness.• During the installation and operation of the inverter, please ensure that the positive or negative poles of PV strings do not short-circuit to the ground. Otherwise, an AC or DC short-circuit may occur, resulting in equipment damage. The damage caused by this is not covered by the warranty.• Input terminals of the PV inverter apply only to input terminals of PV String do not connect any other DC source to the input terminals.• Before connecting PV Arrays ensure that its voltage is within the safe range.• Before touching the DC cables, operator must use a measuring device to ensure that the cable is voltage-free.• The operator must follow all warnings on the PV strings and in its manual.• All electrical connections must be in accordance with local and national standards. Only with the permission of the local utility grid company, the inverter can be connected to the utility grid.• Comply with the safety instructions related to PV strings and the regulations related to the local grid.

2.6 Maintenance and Replacement



DANGER

- High voltage generated by the equipment during operation may cause an electric shock, which could result in death, serious injury, or serious property damage. Prior to maintenance, power off the equipment and strictly comply with the safety precautions in this document and relevant documents.
- Maintain the equipment with sufficient knowledge of this document and using proper tools and testing equipment.
- Before maintaining the equipment, power it off and follow the instructions on the delayed discharge label to ensure that the equipment is powered off.
- Turn off the AC and DC switches of the inverter when maintaining the electric equipment or power distribution equipment connected the inverter.
- For personal safety maintenance personnel must wear appropriate personal protective equipment (like insulation gloves and protective shoes) for the inverter maintenance.
- Place temporary warning signs or erect fences to prevent unauthorized access to the maintenance site.
- Follow the procedures of maintenance stipulated in the manual strictly.
- Check the relevant safety and performance of the inverter rectify any faults that may compromise the inverter security performance before restarting the inverter.
- To avoid any other unforeseeable risk, contact immediately your dealer, if there is any issue found during operation.
- The equipment can be powered on only after all faults are rectified. Failing to do so may escalate faults or damage the equipment.

2.7 PE Connection and Leakage Current

- All inverter is incorporate a certified internal Residual Current Monitoring (RCM) in order to protect against possible electrocution and fire hazard in case of a malfunction in the PV array, cables or inverter.
- There are 2 trip thresholds for the REMA as required for certification (IEC 62109-2:2011). The default value for electrocution protection is 30mA, and for slow rising current is 300mA.
- The inverter, with built-in RCM, will exclude possibility of DC residual current to 6mA, thus in the system an external RCD (type A) can be used ($\geq 30\text{mA}$).



WARNING

- High leakage Current!
- Earth connection essential before connecting supply.
- A faulty ground connection can result in equipment failure, personal and death injuries, and electromagnetic interference.
- Ensure correct according to grounding to IEC62109 and conductor diameter according to STANDARD specification.
- Do not connect the grounding end of the equipment in series to prevent multi-point grounding.
- Electrical appliances must be installed in accordance with the wiring rules of each country.

For United Kingdom

- The installation that connects the equipment to the supply terminals shall comply with the requirements of BS 7671.
- Electrical installation of PV system shall comply with requirements of BS 7671 and IEC 60364-7-712.
- All protective devices cannot be changed.

- User shall ensure that equipment is so installed, designed and operated to maintain at all times compliance with the requirements of ESQCR22(1)(a)

2.8 EU Declaration of Conformity

Hangzhou Livoltek Power Co., Ltd. hereby declares that the inverter with wireless communication module sold in the European market meets the requirements of the following directives:

- Low Voltage Directive 2014/35/EU (LVD)
Restrictions of Hazardous Substances Directive 2011/65/EU and (EU) 2015/863 (RoHS).
- Waste Electrical and Electronic Equipment 2012/19/EU
- Registration, Evaluation, Authorization and Restriction of Chemicals (EC) No 1907/2006 (REACH).
- You can download the EU Declaration of Conformity on <https://livoltek.com>.

3 Product Introduction

3.1 Product Description

- The inverter is a Three-phase hybrid inverter applicable to both on-grid and off-grid solar system with participation of PV array, battery, loads and grid system for energy management.
- The inverter converts the DC power from the PV array or the battery to the AC power, in conformity with the grid requirements. It also transmits the DC power from the PV panel to the battery. With the bidirectional converter integrated inside, the inverter can charge or discharge the battery.
- Several protective functions are integrated in the inverter, including short circuit protection, grounding insulation resistance surveillance, residual current protection, anti-islanding protection, overvoltage and over-current protection, etc.

3.2 Application Scenarios

- PV system is not suitable to connect equipment that relies on a stable power supply, such as: medical equipment to sustain life. Ensure that no personal injury is occurred when the system is disconnected.
- The BACK-UP function is not recommended if the PV system is not configured with batteries. Otherwise, the risk in system power usage is beyond the equipment manufacturer's warranty scope.
- Due to the condition of the battery itself, battery current might be limited by some factors, including but not limited to the temperature and weather.
- Please avoid the following installations which will damage the system or the Inverter. Any damage caused will not be covered by the warranty policy.
 - ① Single PV string cannot be connected to multiple inverters.
 - ② One battery bank cannot be connected to multiple inverters.
 - ③ The EPS (backup) side cannot be connected to the grid.
 - ④ The inverter cannot be connected to any incompatible batteries.

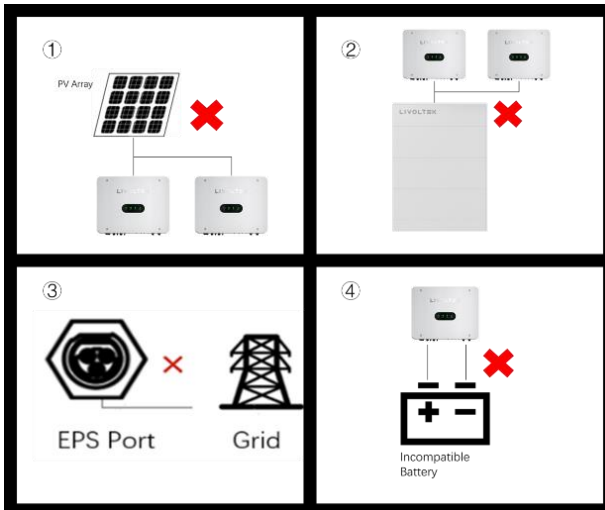

3.3 Power Derating

- Power derating is a way to protect the inverter from overload or potential faults. For a safe operation, the inverter will automatically reduce the output power when the operating environment is not ideal. The following are the factors that may occur power derating. Please try to avoid them during usage.
 - ✧ Unfavorable environmental conditions, e.g., direct sunlight, high temperature, etc.
 - ✧ Over-temperature (including ambient temperature and module temperature).
 - ✧ Power factor (when values out of the rated values)
 - ✧ Over-frequency derating.
 - ✧ Higher input voltage value.
 - ✧ Higher input current value.

3.4 Declaration for Back-Up Function

- The BACK-UP function can provide to the normal household load when the grid is disconnected. To ensure the stability of switching time and load power supply, avoid using loads with higher starting current, such as air conditioner, high-power pump, vacuum cleaner, and hair drier.
- The inverter has the overload protection capability. When single overload protection occurs, the inverter can restart automatically; however, the restarting time will be extended if it happens several times. For a faster restarting, try to turn off the large loads and ensure the load power is within maximum limitation or remove the loads which may cause very high start-up current surges.

NOTICE
<ul style="list-style-type: none">• Appliances such as air conditioner are required at least 2~3 minutes to restart because it's required to have enough time to balance refrigerant gas inside of circuits. If a power shortage occurs and recovers in a short time, it will cause damage to your connected appliances.• To prevent this kind of damage, please check manufacturer of air conditioner if it's equipped with time-delay function before installation. Otherwise, this inverter will trig overload fault and cut off output to protect your appliance but sometimes it still causes internal damage to the air conditioner.

3.5 System Architecture

The following figure shows inverter application in a PV energy storage system.

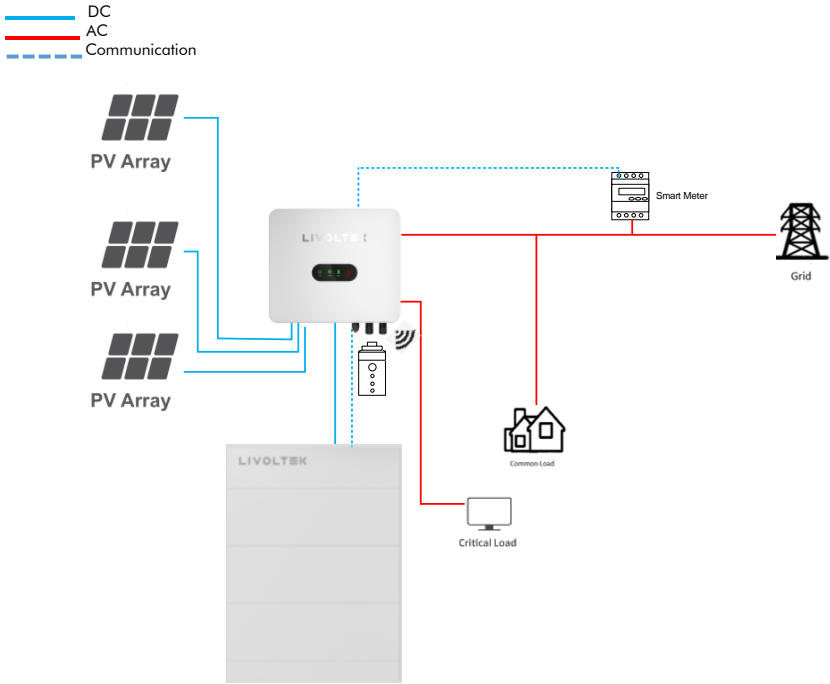

Description	Note
PV Module	PV string is composed of series connected PV panels.
Critical Load	Protected house loads, connected to inverter EPS (backup) port, which need uninterrupted power supply.
Common load	Normal household loads, which will be lack of power when grid is blackout.
Smart meter	The Smart meter is default delivered with the inverter.
Grid	Utility grid, supported Grid Types: TT, TN-C, TN-S. For the grid structure with N cable, the effective value of the voltage between the neutral wire and the ground wire must be less than 10V. When the inverter is used in TT system, it is required that the inverter casing must be grounded, and the default ground fault detection function can be turned off through the APP.
Battery	Select the battery model according to the approved battery list.

3.6 Appearance and Dimension

The following figure shows the dimensions of the inverter. The image shown here is for reference only. The actual product received may differ.

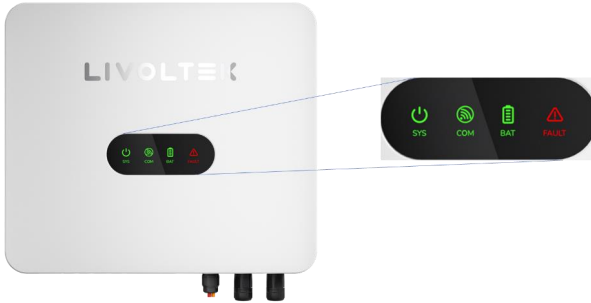

Figure 1. Appearance

Position	Designation
A	System Status Indicator: Reflects the current state of the system.
B	Communication Status Indicator: Reflects the current communication status of the inverter with the meter and the WIFI module
C	Battery status indicator: Reflects battery charging and discharging conditions, battery SOC, communication and other information
D	Fault indicator: This indicator is not illuminated when there is no fault in the system, but is illuminated when a fault occurs.

The following figure shows the dimensions of the inverter.

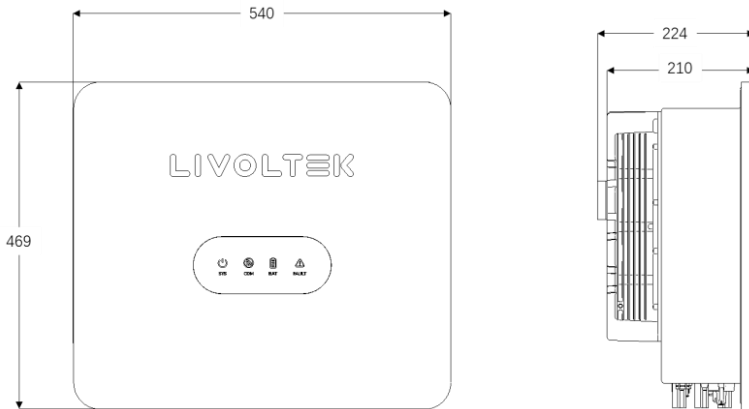

Figure 2. Dimension

3.7 Terminal Description

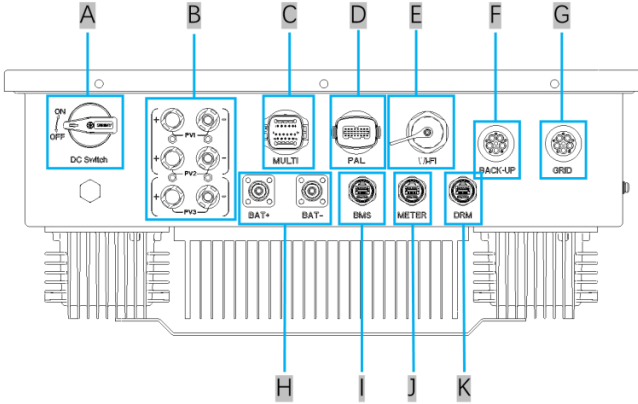

Figure 3. Terminals on the inverter

Position	Description
A	DC Switch
B	PV Input Terminal (The terminal number depends on inverter model)
C	Communication Port for a stick logger
D	COM(Communication) Terminal for communication between inverters in a parallel system
E	Multi COM(Communication) Terminal for EV charger, Dry and other extended function such as generator, etc.
F	AC Terminal for backup loads
G	Grid Terminal for connection to the utility grid
H	Battery Input Terminal (BAT+/BAT-)
I	BMS Communication Port for communication between the inverter and the Li-Ion battery.
J	Commucation terminal for meter
K	DRM Terminal block for connecting to a demand response enabling device (With DRM, NS protection or ripple control)

Note: The image shown here is for reference only. The actual product received may differ.

3.8 Work Modes

The hybrid inverter offers four operating modes (Self-use, ToU, backup and off-grid) based on different requirements. Which can be configured via LIVOLTEK APP for you to determine which mode will be best for you.

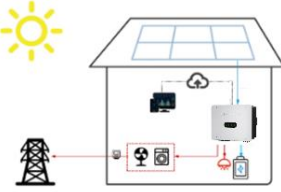
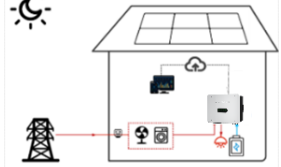
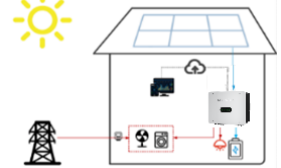
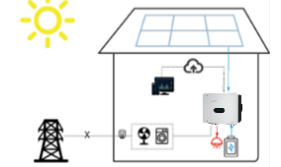
Work Modes	Description
<p style="text-align: center;">Self-Use</p> 	<p>The self-use mode is suitable for areas with the low import rate and high electricity price. The purpose of this mode is to maximize the solar energy usage and lower the power import from the grid.</p> <ul style="list-style-type: none"> • When the power of PV is sufficient, the power generated from PV will be used to supply the loads first, the excess energy is used to recharge the batteries, any remaining excess is then exported to the grid (if allowed) . • When PV energy is insufficient or without PV power, the battery bank will discharge to support critical loads. And when the battery is insufficient, the grid will power the loads.
<p style="text-align: center;">ToU Mode</p> 	<p>The ToU mode is suitable for areas with time of use tariffs which means prices vary between peak and valley.</p> <ul style="list-style-type: none"> • The purpose of this mode is to help the customer using the solar energy at times that best suit them to reduce influence of power price hikes and reduce energy costs. • During the set time period, it will charge or discharge the battery using timed schedules. And during the non-set time period, it will work in self-use mode.
<p style="text-align: center;">Backup Mode</p> 	<p>The Backup mode is suitable for areas with unstable grid to prolong the autonomy in the event of grid outage. Or reducing the frequency charging and discharging of battery to extend battery life.</p> <ul style="list-style-type: none"> • This work mode will ensure the battery reserves a minimum capacity fully charged (can be set via APP) for when there is a grid outage. • The battery will never discharge when the capacity is lower than the set value when the grid is on.
<p style="text-align: center;">Off-grid Mode</p> 	<p>The Off-grid mode is suitable for non-grid areas, and the inverter will automatic activation this mode in the event of grid failure.</p> <ul style="list-style-type: none"> • When the grid fails, the system will automatically switch to this mode. The critical loads will be powered by PV production and Battery. • Battery is necessary in this mode, and EPS loads shall not exceed the max. output power of batteries.)

Note: Contact us for additional or more complex application requirements.

3.8.1 On-Grid Self-Use Mode

The on grid self-use operating mode is recommended for when the system is installed in an area with a stable grid. The purpose is to increase self-consumption of PV energy and save electricity costs.

When Inverter is set to work in this mode:

- **During daytime and there is sufficient PV Power,**
 - ◇ The PV energy is used to supply local loads as first priority and then charge the battery, any excess energy will be fed into grid *1.
 - ◇ When battery is fully charged, PV energy is supplied to the local loads and fed into grid*1.

- **During nighttime or there is not sufficient PV Power,**
 - ◇ Battery is discharged to supply local loads until reaches its power limit*2, if extra power is required, it will be imported from grid.
 - ◇ The battery will stop to discharge when the value is lower than the discharge cut-off value, which is available for setting, the local loads will be supplied from the grid.
 - ◇ The switch from battery power, PV power and grid power is automatic and seamless.

- **When grid fails,**

In the event of a grid failure or there's no mains, the hybrid inverter automatically switches to Off-grid operation mode. The off-grid mode ensures that the system forms a battery-backup grid that utilize power from PV production and battery to supply power to critical loads.

NOTICE
*1: The inverter can be set not to feed power into the grid. But a small amount of energy will still inevitably be fed into grid due to unpredictable PV power changes and load fluctuations. *2: The battery power supply can be restored when the battery is charged to the "set value +10%" by solar.

3.8.2 On-Grid ToU Mode

When operating in this mode, the charging and discharging time can be set flexibly as required. This mode is ideal for those who want to store the power in the battery when the electricity price is at an off-peak rate and use the power during peak rate time or save the energy for grid outages.

- ◇ During charge time, solar energy and grid will charge the battery bank as first priority at the same time, any excess PV energy will supply local loads and then be fed into the grid*1.
- ◇ During discharge time, PV power will supply local loads first, then excess PV power and battery power will be fed into grid*1.
- ◇ The inverter will automatically work in Self-Use mode outside the set time of Charge or Discharge.

NOTICE
*1: The inverter can be set not to feed power into the grid. But a small amount of energy will still inevitably be fed into grid due to unpredictable PV power changes and load fluctuations. *2: The battery power supply can be restored when the battery is charged to the "set value +10%" by solar.

3.8.3 On-Grid Backup Mode

Keep the battery at a high level (default 50%, which is available for setting) for areas with unstable grid that need a large amount of battery to support the emergency use in the event of grid outage. Or reducing the frequency charging & discharging of battery to extend battery life.

- ◇ When there is grid connected, the battery is only allowed to discharge when its capacity is above the set value.
- ◇ When the capacity of the battery power is less than the set value, the solar energy and grid will charge battery to the set value as first priority. If the PV energy is sufficient, it will fully charge the battery and the excess power will be fed to the grid*¹.
- ◇ The loads will be supplied by the surplus solar production supplemented, if necessary, by the public electricity grid.

NOTICE

*1: The inverter can be set not to feed power into the grid. But a small amount of energy will still inevitably be fed into grid due to unpredictable PV power changes and load fluctuations.

*2: The battery power supply can be restored when the battery is charged to the "set value +10%" by solar.

3.8.4 Off-Grid Mode

When operating in this mode, Photovoltaic and battery constitute a pure off-grid system, the critical loads (EPS Loads) will be powered by PV production and if the PV production is insufficient, battery will discharge to power the loads at the same time. (Battery is necessary in this mode.)

NOTICE

●When battery is discharged to the discharge cut-off value (@EPS), the inverter will stop working and wait for the grid to recover or until there is sufficient power from PV panels to charge the battery.











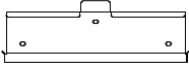
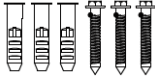

●If grid failure is a common occurrence in your area, it is recommended to adjust the discharge cut-off value (@Grid) higher to ensure there is more battery power available.

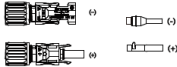
4 Unpacking and Storage

The inverter is thoroughly tested and strictly inspected before delivery. Damage may still occur during shipping. Please check the outer packing for damage and the inner contents for any visible damage. Contact your distributor immediately in case of any damaged or missing components.

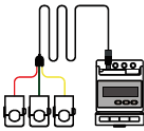
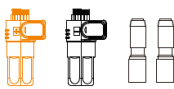
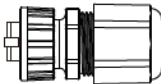
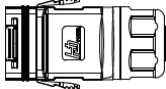
4.1 Packing List

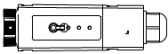
Check if all the accessories are in the package, the standard accessories are listed as below:

 <p>A</p>	 <p>B</p>	 <p>C</p>	 <p>D</p>
 <p>E</p>	 <p>F</p>	 <p>G</p>	 <p>H</p>
 <p>I</p>	 <p>J</p>	 <p>K</p>	 <p>L</p>
 <p>M</p>	 <p>N</p>	 <p>O</p>	 <p>P</p>
 <p>Q</p>	 <p>R</p>	 <p>S</p>	





Position	QTY	Designation
A	1	Inverter
B	1	Wall Mounting Bracket
C	3 pairs	Expansion Bolts
D	2	Spare Screws
E	1 pair	AC Plug for Grid (black) *1 and AC Plug for EPS (grey) *1
F	10	Pin Terminals for Grid/ EPS
G	3 pairs	PV Connectors and PV Terminals
H	1	MULTI Connector (16 pin)
I	16	16 Pin Terminals
J	1	Fixed Screw
K	1	PE Cable Terminal
L	1	Smart Meter
M	1 pair	Battery Connectors and Battery Terminals
N	3	RJ45 Connector for BMS & DRM & Meter
O	1	PAL Terminal
P	8	8 Pin Terminals
Q	1	Stick Logger
R	1	L-type Hexagon Wrench
S	3	Documents

Note: If anything is missing, please contact your local distributor.

4.2 Identification Label

4.2.1 Nameplate











After moving the hybrid inverter from package, identify it by reading its nameplate labeled on the side of the inverter. The nameplate contains important product information: the model information, technical specifications and compliance symbols.

	
Hybrid Inverter Model Name: HP3-12KD2	
	
	
PV Input	
Max. PV Voltage	1000V d.c.
MPPT Voltage Range	150V - 950V d.c.
Max. PV Current	32/16Ad.c.
PV Igc	40/20Ad.c.
AC Input/Output	
Rated AC Voltage	3/N/PE 380/400/415V
Rated AC Frequency	50/60Hz
Max. AC Input Bypass / apparent Power	21.0kW / 21.0kVA
Max. AC Input Bypass Current	31.0A
Rated Output/Apparent Power	12.0kW / 12.0kVA
Rated Output Current	18.2A
Max. Output Power / Apparent Power	12.0kW / 12.0kVA
Max. Output Current	18.2A
Max. EPS Output power / Apparent Power	13.2kW / 13.2kVA
Max. EPS Output Current	20.0A
Power Factor Range	-0.8~+0.8
Battery	
Battery Type	Li-ion
Battery Voltage Range	100-700V d.c.
Max. Charge Power	15.0kW
Max. Discharge Power	12.0kW
Max. Charge Current	50A
Max. Discharge Current	50A
Others	
Overvoltage-Category	DCII / ACIII
Operating Temperature Range	-25°C to +60°C
Max. Operating Altitude	2000m
IP Protection	IP 55
Protective Class	Class I
	
Hangzhou Livoltek Power Co., Ltd. Add: 1418-35, Moganshan Road, Hangzhou City, China web: www.livoltek.com	
MADE IN CHINA HP3-12KD2_Livoltek1.0_01	

Note:

The nameplate shown here is for reference only. The actual product received may differ.

4.2.2 Compliance and Safety Symbols

Symbol	Explanation
	CE marking The product complies with the requirements of the applicable EU directives.
	UKCA marking The inverter complies with the requirements of the applicable UKCA guidelines.
	UKNI marking The inverter complies with the requirements of the applicable UKNI guidelines.
	Caution! Beware of a danger zone! Failure to observe any warnings contained in this manual may result in injury.
	Danger! Beware of hot surface! The inverter can become hot during operation.
	Danger! Beware of high voltage and electric shock! Beware of electrical voltage, the product operates at high voltages.
	Observe the documentation. Observe all documentation supplied with the product.
	WEEE designation. Do not dispose of the product together with the household waste but in accordance with the disposal regulations for electronic waste applicable at the installation site.
	RCM marking Regulatory compliance mark.
	Danger to life due to high voltage and electric shock! There are residual voltages in the inverter after powering off, you should wait at least 5mins after disconnecting the inverter from the utility grid and from the PV panel before touching any inner live parts.

Note: The table shown here is for reference only. The actual product received may differ.

4.3 Storage of Inverter

The following requirements should be met if the inverter will not be deployed immediately:

- Do not unpack the inverter (put desiccant in the original box if the inverter is unpacked).
- Store the inverter at a temperature range of -30°C to $+70^{\circ}\text{C}$, and with the relative humidity of 0% to 100% (no condensing).
- In case of stacking storage, the number of stacking layers should never exceed the limit marked on the outer side of the packing case.
- The inverter should be stored in a clean and dry place and be protected from dust and water vapor corrosion.
- Do not store the inverter in places susceptible to direct sunlight, rain, and strong electric field.
- Do not store the inverter in places with corrosive substances or susceptible to rodents and insects.
- Carry out periodic inspections. Inspection shall be conducted at least once every six months. • If any insect or rodent bites are found, replace the packaging materials in time.
- If the inverter has been stored for more than a year, inspection and testing by professionals are required before it can be put into operation.
- If the inverter needs to be transported again, pack it strictly before transporting it.

NOTICE

- Please store the inverter according to the storage requirements. Product damage caused by failure to meet the storage requirements is not covered by the warranty.

5 Installation

5.1 Installation Requirements

NOTICE	
<ul style="list-style-type: none">• Make sure there is no electrical connection before installation.• In order to avoid electric shock or other injury, make sure that holes will not be drilled over any electricity or plumbing installations.• Always follow the instructions when moving or positioning the inverter.• Improper operation may cause injuries or serious wounds. In the case of poor ventilation, the system performance may compromise.	

5.1.1 Location Requirements

Select an optimal mounting location for safe operation, long service life and expected performance.

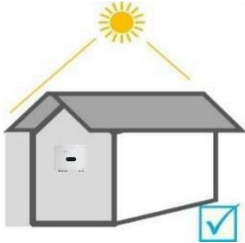

No direct sunlight



No rain exposure

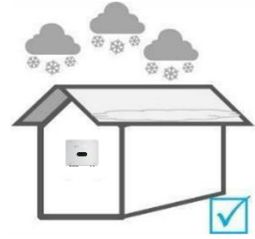

No snow lay up

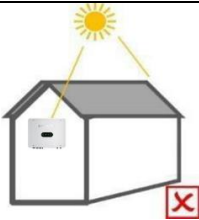

Direct sunlight



Rain exposure



Snow lay up

Note:

- **AVOIDE** direct sunlight, rain exposure, snow laying up during installation and operation.
- **DO NOT** install the inverter in a place where personnel are likely to come into contact with its enclosure and heat sinks because these parts are extremely hot during operation.

5.1.2 Environment Requirements

The inverter must be installed in a ventilated environment to ensure good heat dissipation.

Make sure the installation meets the following conditions:

- Not in areas where highly flammable materials are stored.
- Not in potential explosive areas.
- Not in the cool air directly.
- Not near the television antenna or antenna cable.
- Not higher than altitude of about 2000m above sea level.
- Not in environment of precipitation or humidity (>95%).
- The slope of the wall should be within $\pm 5^\circ$.
- The wall must be solid enough to bear the weight of the inverter.
- Do not install the inverter on a wall made of gypsum boards or similar materials with weak sound insulation to avoid noise disturbance in a residential area.

5.1.3 Angle and Space Requirements

NOTICE

- Never install the inverter horizontally, or with a forward tilt or with a backward tilt or even with upside down. The horizontal installation can result in damage to the inverter.
- Install the inverter upright or at a maximum back tilt of 15 degrees to facilitate heat dissipation.

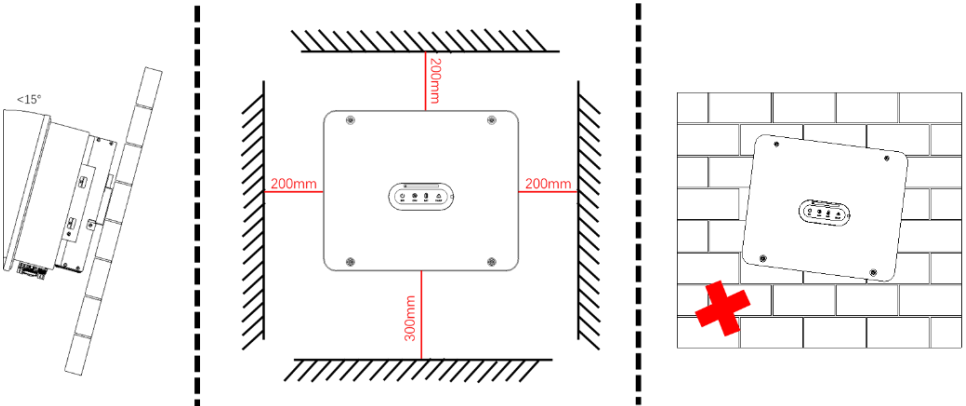

5.1.4 Tools Preparation

Installation tools recommended but not limited to the following ones. If necessary, use other auxiliary tools on site.

 Bit $\Phi 10$ Hammer drill	 Rubber hammer	 Tape ruler	 Spirit level\Marker
 Protective glasses	 Dustproof Cover	 OT terminals press clamp	 Wire stripper
 DC Voltage (Range $\geq 1100V$ DC) Multimeter	 Euro terminal crimping tool	 Diagonal pliers	 Multifunction terminal crimping tool (RJ45)

5.2 Mounting Instruction

Installation:

- Hybrid inverters and batteries can be wall-mounted or floor-mounted
- The inverter must be connected with the Li-Ion battery of LIVOLTEK brand. And there are two independent packages (inverter and battery kits) for the installation. Please check and contact your distributor immediately in case of any damaged or missing components.

5.2.1 Mounting the Inverter

Step1: Drill holes on the wall

- Take out the wall-mounting Bracket from the inverter package.
- Locate the appropriate drilling holes and mark it with a marker pen (Using a digital level to make sure the bracket is at a horizontal position before installation.)
- Drill holes with driller, make sure the holes are deep enough (at least 50mm) to support the inverter.

Step 2: Secure the mounting bracket on the wall

- Use expansion bolts or correct wall fixings to attach the mounting bracket to the wall tightly.

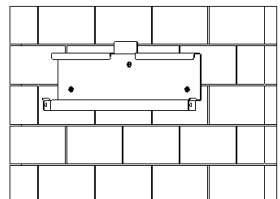
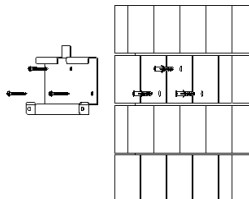
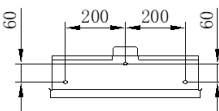

NOTICE

- The inverter must not be installed near flammable or explosive materials or near the equipment with strong electromagnetism.
- The inverter is suitable for mounting on concrete or other non-combustible surfaces only.
- The bearing capacity of the wall must be greater than 50kg. Otherwise, the wall may not be able to prevent the inverter from dropping.

Step 3: Mount the inverter to the mounting bracket

- Carry the inverter by holding the heat sink on two sides and hang the inverter on the mounting bracket. And then lock the side with screw.

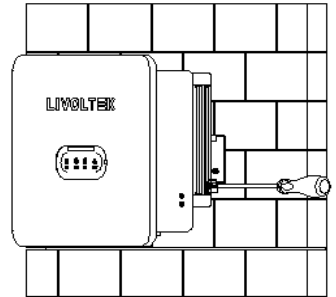
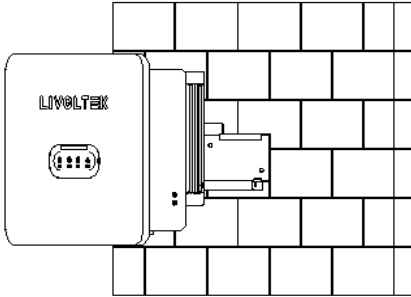

Step 4: Installation Self-check

- Ensure the inverter is well fixed;
- Ensure DC-switch is switched to OFF.

Step 5: Electrical Connection

Please refer to the Electrical Connection instructions in the next chapter.

6 Electrical Connection

Prior to any electrical connections, keep in mind that the inverter has dual power supplies. It is mandatory for the qualified personnel to wear personal protective equipment (PPE) during the electrical work.



DANGER

Danger to life due to a high voltage inside the inverter!

- The PV strings will generate lethal high voltage when exposed to sunlight. Before starting electrical connections, disconnect the DC and AC circuit breakers and prevent them from inadvertent reconnection.
- All operations, cables and parts specification during the electrical connection shall be in compliance with local laws and regulations.
- Disconnect the DC switch and the AC output switch of the inverter to power off the inverter before any electrical connections. Do not work with power on. Otherwise, an electric shock may occur.



WARNING

- Any improper operations during cable connection can cause device damage or personal injury.
- Wear personal protective equipment like safety shoes, safety gloves, and insulating gloves during electrical connections.
- Only qualified personnel can perform cable connection.
- All cables must be firmly attached, undamaged, properly insulated and adequately dimensioned.

NOTICE

- Comply with the safety instructions related to the PV strings and the regulations related to the utility grid.
- All electrical connections must be in accordance with local and national standards.
- Only with the permission of the utility grid, the inverter can be connected to the utility grid.
- When the inverter is powered on, the EPS(BACK-UP) port is charged. Power off the inverter first if maintenance is required for the loads connected with EPS port. Otherwise, it may cause electric shock.

Note:

1. The cable colors shown in the electrical connection diagrams provided in this chapter are for reference only. Select cables in accordance with local cable specifications (green and yellow cables are only used for PE).
2. Flexible cables are recommended for power connections in the following wiring procedures. Additionally, corrugated conduits should be installed for power cables connected to each inverter port.

6.1 Wiring Diagram

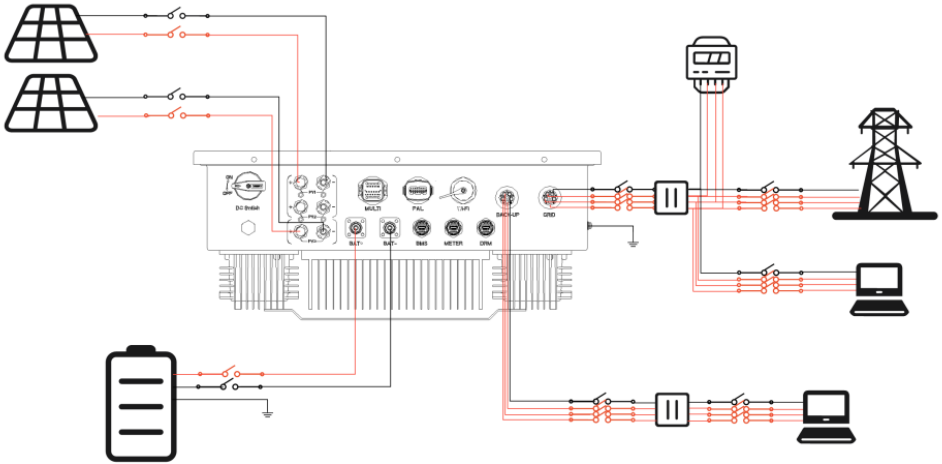

WARNING

- N and PE wiring via ON-GRID and BACK-UP ports of the inverter are different based on the regulation requirements of different regions. Refer to the specific requirements of local regulations.
- For the GRID side, it is recommended to connect a 300mA circuit breaker unless local codes mandate the use of 30mA.
- For Australia, New Zealand and South Africa, the neutral cable of GRID side and BACK-UP side must be connected together, otherwise EPS(BACK-UP) function will not work.
- In Australia and New Zealand, electrical installation and maintenance shall be conducted by a licensed electrician and shall comply with Australia/New Zealand National Wiring Rules. Because the inverter does not maintain neutral integrity, an external neutral connection must be used in Australia and New Zealand. 30mA Type "A" RCD can be used where required by AS/NZ_3000, but cannot be used if there are backup loads on the inverter as per AS4777.
- If the battery is integrated with a readily accessible internal DC breaker, no additional DC breaker is required.

6.2 External Grounding (PE Cable) Connection

6.2.1 External Grounding Requirements

Good grounding for the inverter helps resist the impact of surge voltage and improve the EMI performance. Connect the PGND cable before connecting the AC power cables, DC power cables, and communication cables.



WARNING

- Ensure that the PE cable is securely connected. Otherwise, electric shocks may occur.
- Do not connect the neutral wire to the enclosure as a PE cable. Otherwise, electric shocks may occur.

NOTICE

- The PE point at the AC output port is used only as a PE equipotential point, and cannot substitute for the PE point on the enclosure. Make sure the two terminals are both grounded reliably.
- It is recommended that silica gel or paint be used around the ground terminal after the PE cable is connected.

6.2.2 Wiring Connection Procedure

The PE cable should be prepared by customers. Recommended specifications:

- Type: Outdoor single-core copper wire.
- Conductor cross-sectional area: 10-16mm² (Cannot be smaller than the selected wire diameter of GRID terminal.)

Step1: Crimping OT terminals

- Prepare the cable and remove an appropriate length of the insulation layer from it.
- Insert the exposed core wires into the crimping areas of the OT terminal and crimp them using hydraulic pliers.

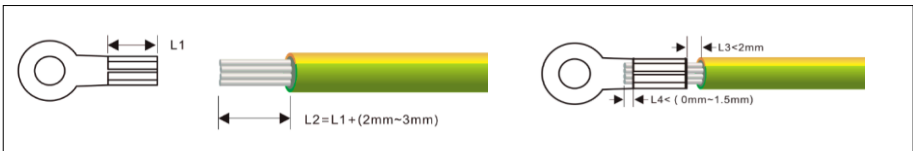

Step2: Connecting the PE Cable

- Remove the screw on the grounding terminal on the side of the inverter and fasten the cable with a screwdriver.
- Apply paint to the grounding terminal to ensure corrosion resistance.

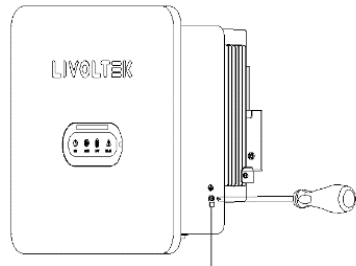

6.3 Grid Port Connection

The hybrid inverter has two AC output terminals, one is grid output for connecting grid and the other is EPS (emergency power supply) output for connecting critical (backup) Loads.

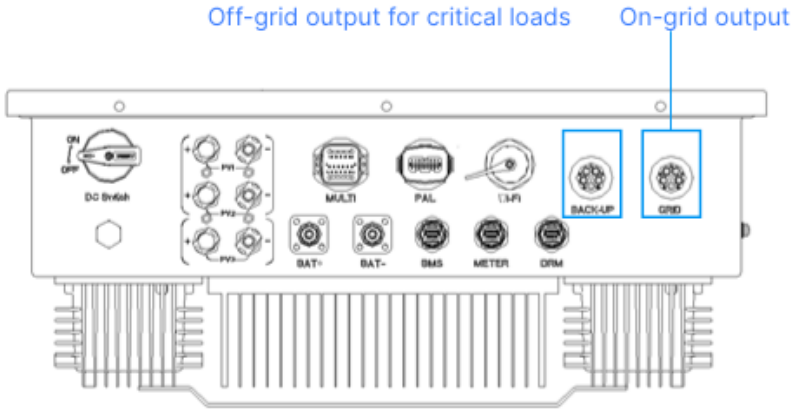

WARNING

- Make sure inverter is totally isolated from any DC or AC power before connecting AC cable.
- Only with the permission of the local grid department, the inverter can be connected to the grid.
- Before commencing AC wiring, please ensure all AC circuit breakers are switched off.
- **DO NOT** connect the AC grid terminal and AC Backup (EPS) terminal together.
- **DO NOT** connect the AC Backup (EPS) terminal to grid.
- When you want to use both on grid power and backup power, please connect both with Grid output and EPS output. When you want to use on grid only, please connect with Grid output and float EPS output.
- Determine whether an AC circuit breaker with greater overcurrent capacity is required based on actual conditions.
- The grid voltage and frequency must be in the permissible range.
- Never connect a load between the inverter and the circuit breaker.

6.3.1 Wiring Connection Procedure

The AC cable should be prepared by customers. And an external AC circuit breaker should be installed on the output side of the inverter and the grid side (between inverter and loads) to ensure safe disconnection from the grid. The recommended specifications are as follows.

Model	Wire Size	Cable	Beaker
HP3-5~8KD2	10-12AWG	4-6mm ²	400/25A
HP3-10~12KD2 HP3-5~6KL2	10-12AWG	4-6mm ²	400/32A

Step1: Assembling the Grid Connector

- Take out the AC terminal from the package box and uninstall it as below chart.
- Put the AC cables through the terminal cap, threaded sleeve in sequence.
- Remove the cable jackets and strip the wire insulation by 5~7 mmm then insert cables into connection terminals according to polarities indicates on it and tighten the screws.
- Push threaded sleeve onto the connection terminal until both are locked tightly.
- Screw up the terminal cap.

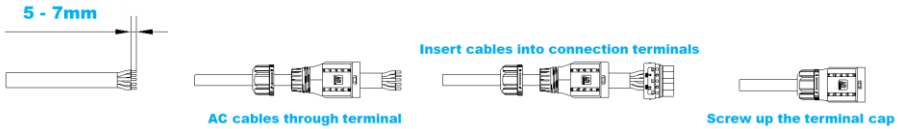

Step 2: Connecting the Grid terminal into the Grid Port on the inverter

- Unscrew the cap on the Grid port.
- Insert the Grid connector into the Grid port on the bottom of the inverter.
- Check all the wires are firmly installed.

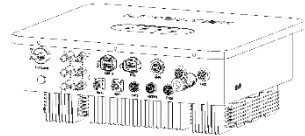

6.3.2 Residual Current Monitoring Device

With an integrated universal current-sensitive residual current monitoring unit included, the inverter will disconnect immediately from the mains power once a fault current with a value exceeding the limit is detected. However, if an external residual current device (RCD) (type A is recommended) is mandatory, the switch must be triggered at a residual current of 300 mA (recommended). RCD of other specifications can also be used according to local standard.

6.4 EPS Output Connection

If you want to use the energy storage system to power the house (as a standalone system or during Grid failure), the EPS connector should be used and the EPS function should be enabled during setup. Otherwise, you could leave the EPS port disconnected.

The EPS output port is only for critical loads connection.



WARNING

- The grid voltage and frequency must be in the permissible range.
- Risk of inverter damage due to incorrect cable connection. Do not connect the grid power wires to EPS port.
- An independent circuit breaker must be installed on the EPS side to cut off the inverter from EPS loads when necessary.
- Decide which household appliances should be included in the EPS circuit and carry out any required re-wiring.

Wiring Connection Procedure:

Step 1: Assembling the EPS Connector (reference to Grid connector).

Make sure Live/Neutral/PE wires are correct.

Step 2: Connecting the EPS cable to the inverter

- Unscrew the cap on the EPS port.
- Insert the EPS cable into the EPS port on the inverter until there is a "Click" sound.
- Check all the wires are firmly installed.

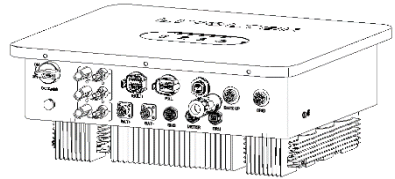

6.5 PV Connection



DANGER

Danger of electric shock!

- The PV array will generate lethal high voltage once exposed to sunlight. Ensure all cables are voltage-free before performing electrical operations.
- Do not connect the AC circuit breaker before finishing electrical connection.



WARNING

- Make sure the PV arrays are well insulated to ground before connecting it to the inverter.
- Make sure the voltage, current and power ratings of the PV arrays are within the permissible range.
- Make sure polarity is correct. The inverter will not function properly if any PV polarity is reversed.
- The 5 - 12kW inverter is designed with 2 MPPT trackers, if the inputs of the PV panels are paralleled, please consult with your local distributor for technical support.
- To avoid any malfunction, do not connect any PV Arrays with possible current leakage to the inverter. For example, grounded PV Arrays will cause current leakage to the inverter.
- Make sure DC switch on "OFF" position. Otherwise please use an external PV switch to cut off the PV connection during wiring and when necessary.

NOTICE

- Use IEC61730 class-A Rating PV Arrays.
- To ensure IP65 protection, use the right PV plugs in the package.
- Damage to the device due to the use of incompatible terminals shall not be covered by the warranty.
- All wiring must be performed by qualified personnel.

Wiring Connection Procedure:

The cable should be prepared by customers. LIVOLTEK provides corresponding PV connectors in the scope of delivery for quick connection of PV inputs. To ensure IP65 protection, use only the supplied connector or the connector with the same ingress of protection.

Model	Wire Size	Cable	Recommended parameters for breakers
5-12kW	10-12AWG	4-6mm ²	1100V/25A (Single string MPPT)

Step1: Assembling the PV Connectors

- Strip the insulation from each PV cable by 6 mm –8 mm.
- Assemble the cable ends with the crimping pliers.
- Lead the cable through the cable gland and insert the crimp contact into the insulator until it snaps into place. Gently pull the cable backward to ensure firm connection.
- Tighten the cable gland and the insulator.

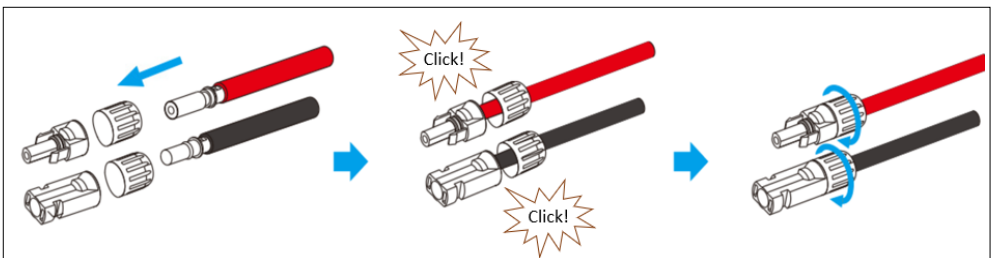
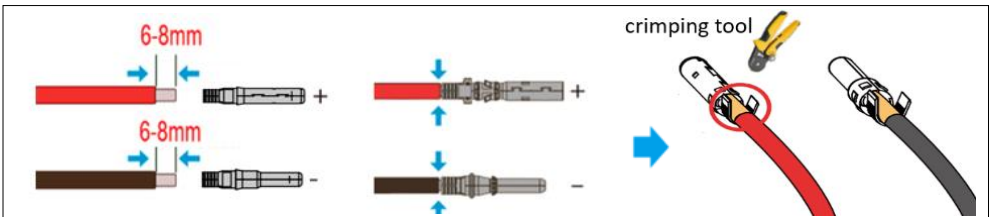

NOTICE

- DO NOT crimp the two metal sheets (below picture).
- These are fixing structure of metal core and its plastic shell. Crimping of the two metal sheets will result in failure of assemble, which may cause contact problems, and even fire in extreme cases.
- Check the cable connection of the PV string for polarity correctness and ensure that the open circuit voltage in any case does not exceed the inverter input limit of 1000V.

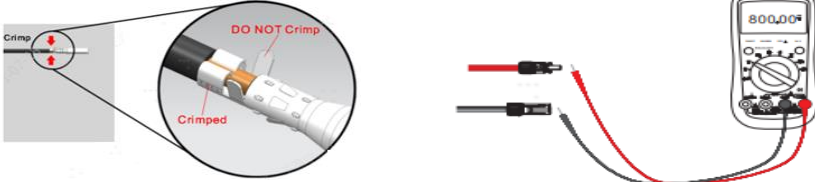

Step 2: Connecting the PV cables to the inverter

- Connect the PV connectors to the corresponding terminals until a “click” sound is heard.
- Seal the unused PV terminals with the terminal caps.

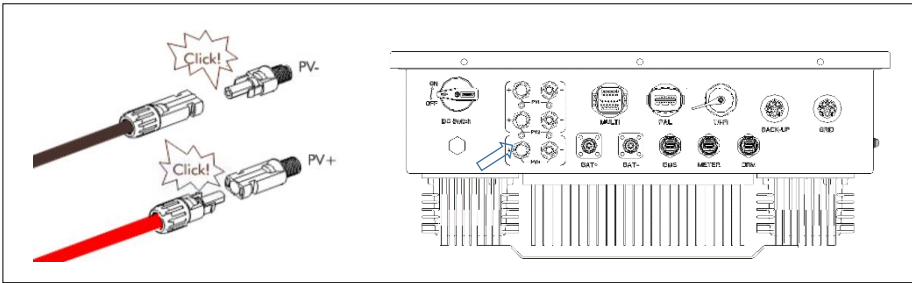

NOTICE

- Before installing the inverter check all electrical ports to ensure no damage and no short circuit, otherwise personal casualty and or fire will occur.
- Check the positive and negative polarity of the PV strings, and connect the PV connectors to corresponding terminals only after ensuring polarity correctness.
- Install the external protective grounding cable first when performing electrical connection and remove the external protective grounding cable last when removing the inverter.
- During the installation and operation of the inverter, please ensure that the positive or negative poles of PV strings do not short-circuit to the ground. Otherwise, an AC or DC short-circuit may occur, resulting in equipment damage. The damage caused by this is not covered by the warranty.
- Arc or contactor over-temperature may occur if the PV connectors are not firmly connected in place, and LIVOLTEK shall not be held liable for any damage caused due to this operation.
- If the DC input is connected inversely and the DC switch has been rotated to "ON", do not operate immediately. Otherwise, the equipment may be damaged. Please turn the DC switch to "OFF" and remove the DC connector to adjust the polarity of the strings when the string current is lower than 0.5A.
- The operator must follow all warnings on the PV strings and in its manual.
- All electrical connections must be in accordance with local and national standards. Only with the permission of the local utility grid company, the inverter can be connected to the utility grid.
- Comply with the safety instructions related to PV strings and the regulations related to the local grid.

6.6 Battery Connection

This section mainly describes the cable connections on the inverter side. Refer to the instructions supplied by the battery manufacturer for the connections on the battery side and configuration.



DANGER

- Be careful against any electric shock or chemical hazard.
- A short circuit in the battery may cause personal injury. The instantaneous high current caused by a short circuit can release a large amount of energy and may cause a fire.
- Ensure that the open circuit voltage of the battery is within the permissible range of the inverter.
- Only use properly insulated tools to prevent accidental electric shock or short circuits. If insulated tools are not available, use electrical tape to cover the entire exposed metal surfaces of the available tools except their tips.
- Before connecting the battery cable, ensure the switches of inverter and the battery are all disconnected.
- Connect battery cables with correct polarity. If battery cables are reversely connected, the solar inverter may be damaged.
- It is forbidden to connect and disconnect the battery cables when the inverter is running, otherwise it may cause electric shock.
- Do not connect one battery pack to more than one inverter at the same time. Otherwise, it may cause damage to the inverter.
- It is forbidden to connect loads between the inverter and batteries.
- During installation and operation of the inverter, make sure that the batteries are not short-circuited to ground. Failure to do so may result in damage to the unit. The resulting damage is not covered by the warranty.
- All wiring must be performed by a professional person.

NOTICE

- The hybrid inverter is not connected to a battery and does not support off-grid operation functions.

6.6.1 Battery Connection

Battery connection diagram

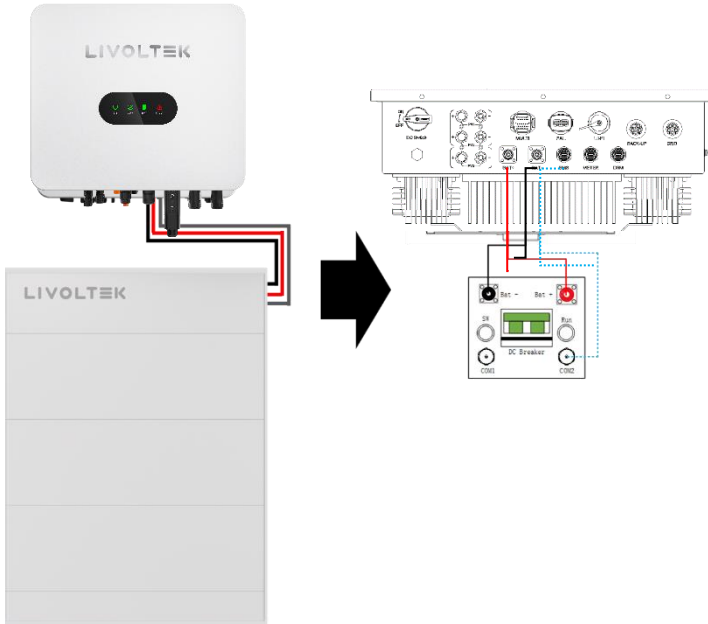

Note:

Please be careful of any electric shock or chemical hazards. For batteries without a built-in DC breaker, make sure that an external DC breaker (800V/63A) connected.

NOTICE

- The battery used with the inverter shall be approved by the inverter manufacturer. This inverter can only be connected with **LIVOLTEK** high-voltage lithium batteries with nominal voltage now. If you choose other lithium batteries, please consult LIVOLTEK for compatibility. Otherwise, the inverter will not work normally.
- For safe operation and compliance, a two-pole DC circuit breaker with overcurrent protection should be installed between the inverter and the battery.
- If you do not have battery now, you can float BAT terminal, and this hybrid inverter will only work like a PV inverter.

Notes:

Prepare battery cables with a conductor cross section of 16mm² because the maximum battery current is 50A. Use the right BAT plugs within the scope of delivery.

- If the connectors of the battery power cables to battery side is not assembled, you need to contact with your battery vendor for detailed information.
- For LIVOLTEK Li-Ion battery, you should cut off one pair connectors of the battery power cables, and change them to water-proof BAT plugs in the inverter package.

Wiring Connection Procedure:**Step 1: Assemble the battery cable Connectors**

- Remove an appropriate length of the insulation layer from the positive and negative power cables using a wire stripper.
- Thread the battery cable through the sleeve of the positive and negative battery connector as below. Insert the stripped end of the cable into the positive and negative battery terminal respectively and crimp them.
- Ensure the correct polarity of batteries before connecting to the inverter.

NOTICE

Before connecting the crimped cable to the battery connector, ensure that the cable is threaded through the sleeve.

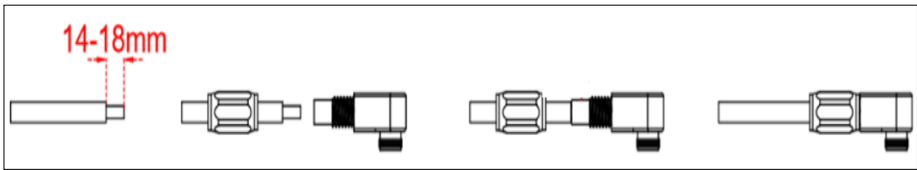
**Step2: Connect the Battery cables to the inverter**

- Insert the battery plugs into the corresponding BAT+ and BAT- terminals at the bottom of the inverter.
- Ensure that the connectors are securely in place.

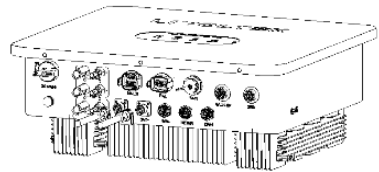
**Step 3: Connect the Battery cables to the Battery**

- Connect the Battery cable to the Battery and make sure the positive and negative poles are correct.
- Refer to the instructions supplied by the battery manufacturer for the connections on the battery side.

6.6.2 BMS Cable Connection

NOTICE

- Make sure to connect the BMS communication cable between the battery and the inverter.
- The CAN cable enables the communication between the inverter and the Li-Ion Battery.
- Communication interface between inverter and battery is CAN with a RJ45 connector.
- The battery communication can only work when the battery BMS is compatible with the inverter.

Wiring Connection Procedure:

Step1: Assemble the BMS cable Connector

- Prepare a communication cable and insert the BMS cable connector which can be found in the accessory box.
- Crimp the communication cable with a RJ45 plug which is inside of the BMS cable connector.

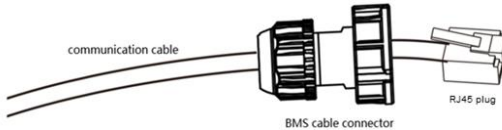

Step2: Connect the BMS cable to the inverter

- Insert the BMS cable connector into BMS port on the inverter and screw it tightly.
- Then insert other side of communication cable into CAN port on the battery.
- Make sure the Li-Ion battery BMS port connects to the inverter is Pin to Pin.

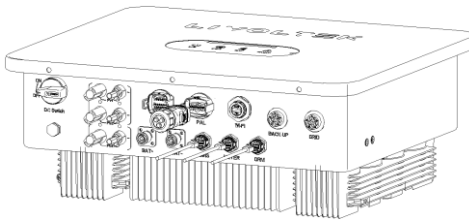







BMS Pin Definition

NOTICE

Make sure the right wire sequence, otherwise will cause failure.

BMS Pin Definition for Li-Ion Battery from LIVOLTEK

	Orange white	1. BMS_CAN_H
	Orange	2. BMS_CAN_L
	Green white	3. NULL
	Blue	4. NULL
	Blue white	5. NULL
	Green	6. NULL
	Brown white	7. NULL
	Brown	8. NULL

6.8 DRM Connection

The inverter supports the demand response modes as specified in the standard AS/NZS 4777. The inverter has integrated a terminal block for connecting to a DRED, as shown in the following figure.

Mode	Requirement
DRM0	Operation disconnect device
DRM1	Do not consume power
DRM2	Do not consume more than 50% of rated power
DRM3	Do not consume more than 75% of rated power AND Source reactive power if capable
DRM4	Increase power consumption (subject to constraints from other active DRMs)
DRM5	Do not generate power
DRM6	Do not generate more than 50% of rated power
DRM7	Do not generate more than 75% of rated power AND Sink reactive power if capable
DRM8	Increase power generation (subject to constraints from other active DRMs)

“DRM” Connector Pin Definition

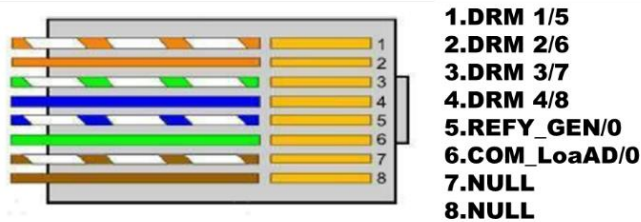

Wiring Connection Procedure:

Step 1: Unscrew the swivel nut from DRM port.

Step 2: Lead the cable through the cable gland.

Step 3: Remove the cable jacket and strip the wire insulation.

Step 4: Plug the wires into the corresponding terminals.

Step 5: Fasten the swivel nut with a torque of 4–5N.m and connect the other end to the DRED (DRED device is not provided by LIVOLTEK).

6.9 MULTI COM Terminal Connection

The inverter provides 16pin terminals to facilitate you to parallel function of EV charger, EMS and other extended functions.

NOTICE

- Follow the pin definition below to connect the Multi com communication cables.
- Do not remove the resistor or short circuit wire unless you are going to use the corresponding PINs.

6.9.1 MULTI COM Terminal Pin

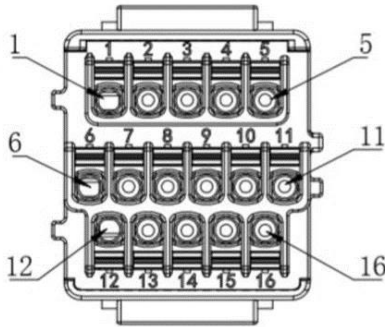

Signal definitions

Pin	Definition	Description	Pin	Definition	Description
1	DO2	DO2, reserved	9	GND	Power for external RSD devices
2	COM2		10	+12V	
3	NULL	/	11	DI-	DI, reserved
4	NULL		12	DI+	
5	DO1	DO1, for diesel generator	13	485A1	Reserved, for EMS device
6	COM1		14	485B1	
7	NULL	/	15	485A2	Reserved, for EV charger
8	NULL		16	485B2	

6.9.2 16pin terminals

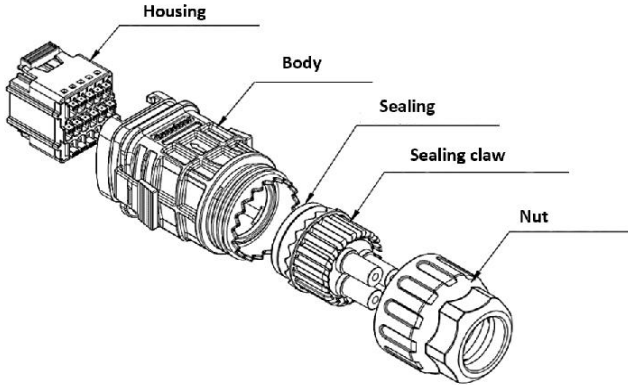

Wiring Connection Procedure:

Step 1: Prepare the communication cable and remove the plug of the communication terminal.

Step 2: Dismantle the communication module and take out the pin terminal. To avoid water and dust, keep the rubber plug to seal the unused holes.

Step 3: Insert the communication cable into the corresponding pins terminal to realize the RS485 communication function.

Step 4: Assemble the communication module and plug it into the communication terminal.

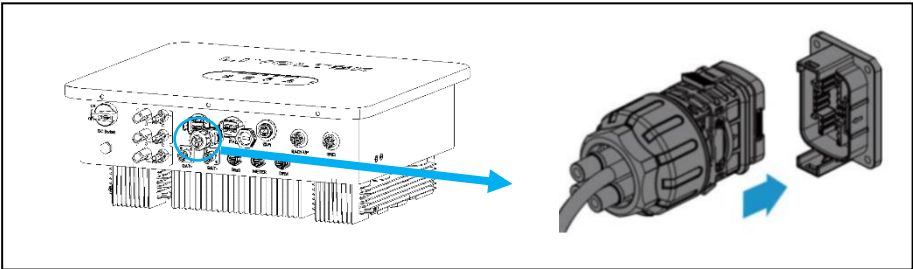

Notes: Assemble the communication module and plug it into the communication terminal directly if you are not going to use the communication functions.

6.9.3 EV charger Connection

This inverter is ready for you to use solar energy to charge your electric car.

For more details, please refer to the LIVOLTEK EV charger user manual.

Notes: This inverter can be only connected with LIVOLTEK EV charger now.

6.9.4 Diesel Generator Connection

A HP3-5~12kW inverter can be matched with a diesel generator.

NOTICE

- If a diesel generator is not connected to the GEN port of the inverter temporarily when a HP3 series inverter is initially installed, it is recommended that the communication cable should be reserved for a diesel generator connection for easy wiring in the future.
- Here below a diesel generator is connected to a single inverter.
- When the inverter is connected to a diesel generator, an ATS is required to be connected between the inverter and the diesel generator.
- The working logic of diesel generator dry contact: when the inverter's internal generator dry contact relay is connected, the diesel generator turns on. When the generator dry contact relay is disconnected, the diesel generator turns off.
- The working logic of ATS dry contact: when the ATS is connected to common power supply feedback signal (the grid), the inverter's internal ATS dry contact relay is connected. When the ATS is connected to backup power supply feedback signal (the diesel generator), the ATS dry contact relay is disconnected.

➤ System Diagram

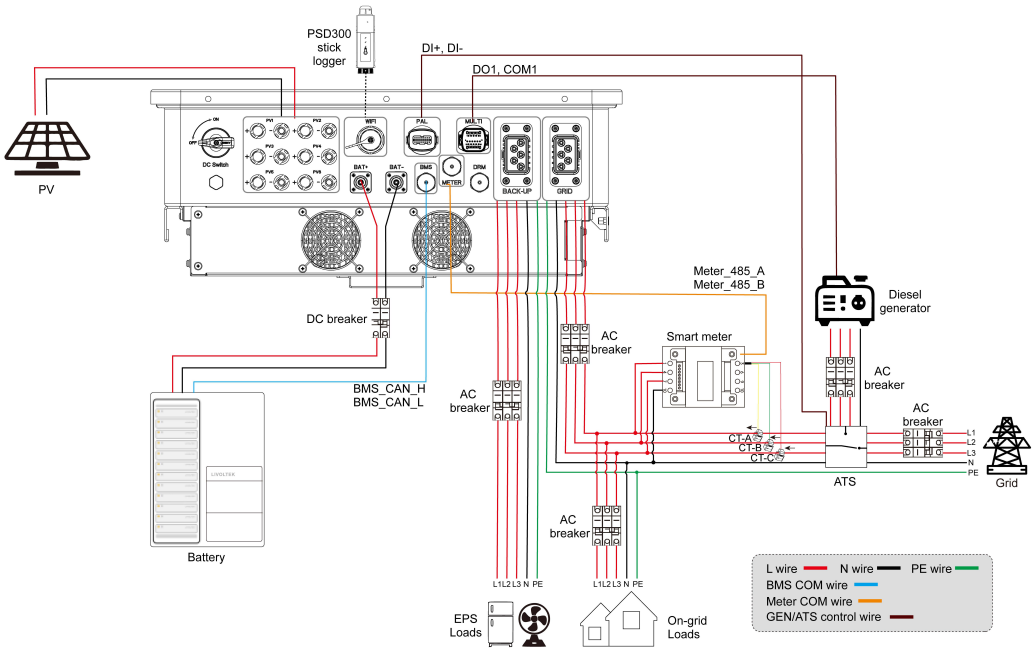

➤ Wiring Procedure

✧ Communication connection between the inverter and the ATS

Prepare a communication cable, connect one end of the cable to the PAL port of the inverter and the other end to the terminals of the ATS.

✧ Inverter Side

Connect one end of the cable to the pin3 and pin4 of the PAL port.

Pin definition of PAL port of the inverter

Pin	Pin Definition
3	DI+
4	DI-

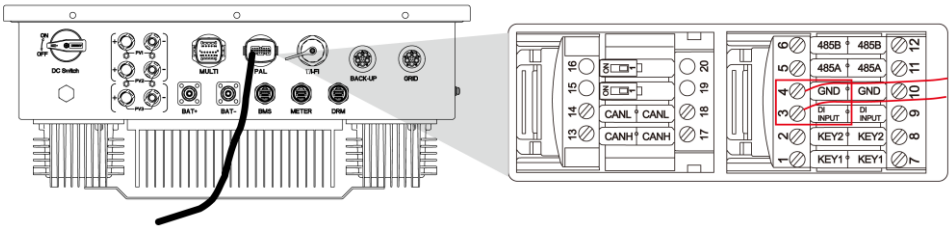

✧ ATS Side

Connect the other end of the cable to the **common power supply feedback signal** of a specific type of ATS connected. Here below 302 and 303 terminals (common power supply feedback signal) of this kind of ATS is taken for an example.

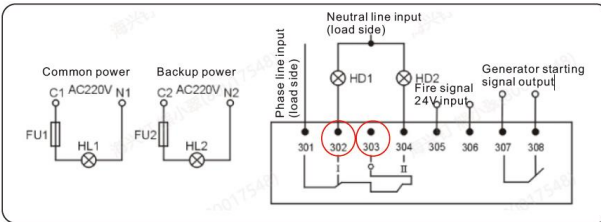

***Note:** Customers must select ATS with feedback signals.

Cable Wiring and Connection

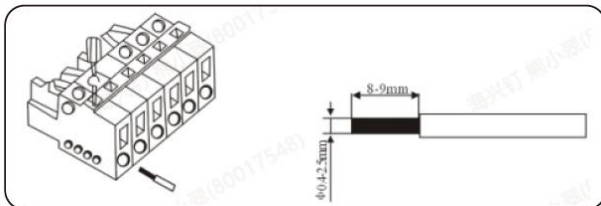

***Note:** DO NOT connect to the high-voltage feedback signal terminals of the ATS, otherwise, the inverter may be damaged.

✧ **Communication connection between the inverter and the diesel generator**

✧ **Inverter Side**

Prepare a communication cable, connect one end of the cable to the pin5 and pin6 of the MULTI port.

Pin	Pin Definition
5	DO1
6	COM1

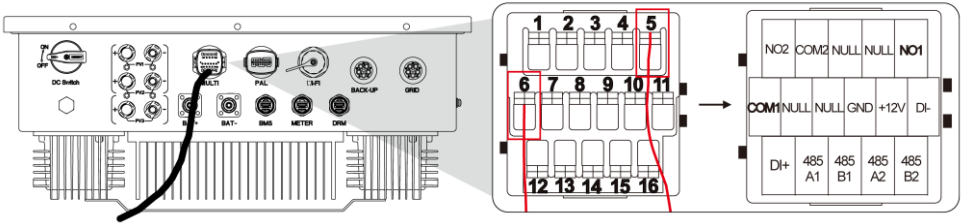

NOTICE

If the diesel generator selected cannot or do not need to be controlled by the inverter, customers do not need to connect to the pin5 and pin6 of the MULTI port of the inverter.

✧ **Diesel Generator Side**

Connect the other end of the cable to the corresponding terminals of the generator. Please refer to the user manual of a specific diesel generator for the communication connection.

NOTICE

Refer to 8.5.6 Diesel Generator Setting to complete the diesel generator settings if one HP3 series inverter is connected to a diesel generator.

6.9.5 Installation Verification

Check the following items after the inverter is installed.

- No other objects put on the inverter.
- All screws especially the screws used for electrical connections are tightened.
- The inverter is installed correctly and securely.
- Ground, AC, DC and Communications cables are connected tightly correctly and securely.
- Check there is no open circuit or short circuits at AC and DC terminals using multi-meter.
- Idle terminals are sealed.
- All safety warning symbols are intact and complete on the inverter.

6.10 Smart Meter Connection

When customer needs to use meter to monitor the energy flow, the meter terminal connection steps are as follows:

NOTICE

- Make sure AC cable is totally isolated from AC power before connecting Smart Meter.
- One Smart Meter can only be used for one hybrid inverter.
- Normally the smart meter should be placed in or near the grid distribution box right after the billing meter.
- Please use the smart meter cable in the accessory box for communication.
- CAT4 and above network cable is recommended to crimped with a RJ45 terminal and connect to the smart meter.

Wiring Connection Procedure:

Step 1: Prepare a network cable, strip the cable and wires respectively, insert the wires into the RJ45 terminal. Crimp the network cable with a RJ45 terminal in accordance with the pin definition below.

Step 2: Connect the end assembled with a RJ45 terminal to the Meter port on the inverter and the pin1(orange white) and pin2 (orange) wires of the other end of the network cable to the pin15 and pin16 terminals on the smart meter respectively.

Step 3: Secure the Meter swivel nut on the inverter.

Meter Connector Pin Definition

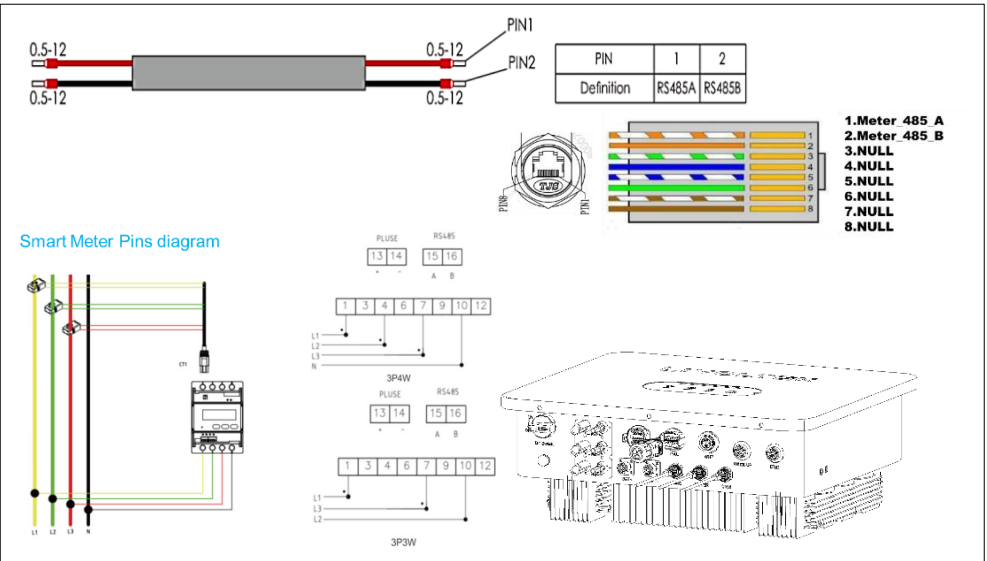

6.11 PAL Connection

When the customer needs to use multiple inverters to build a parallel system, the PAL COM port connection procedure is as follows:

NOTICE

- - Before connecting the inverters, make sure that both inverters can operate normally
- - The inverters to be processed in parallel need to meet the software version requirements.
- - The inverters to be processed in parallel must be of the same model and in the same power band.
- - Before parallel processing, it is recommended to keep the SOC of the batteries of each system as consistent as possible, otherwise it will have an impact on battery life and system performance.

PAL Pin Definition

Pin	Pin Definition	Description
		1&7
2&8	COM	
3&9	DI+	DI, reserved
4&10	DI-	
5&11	485A	For parallel
6&12	485B	
13&17	CAN_H	For parallel
14&18	CAN_L	
15	CAN DIP	Reserved in the parallel system, set the DIP switches to the ON position for the first and the last inverters.
16	485 DIP	

Wiring Connection Procedure:

Step 1: Prepare the communication cable and remove the plug of the communication terminal.

Step 2: Dismantle the communication module and take out the pin terminal. To avoid water and dust, keep the rubber plug to seal the unused holes.

Step 3: Insert the communication cable into the corresponding pins terminal to realize the RS485 communication function.

Step 4: Assemble the communication module and plug it into the communication terminal.

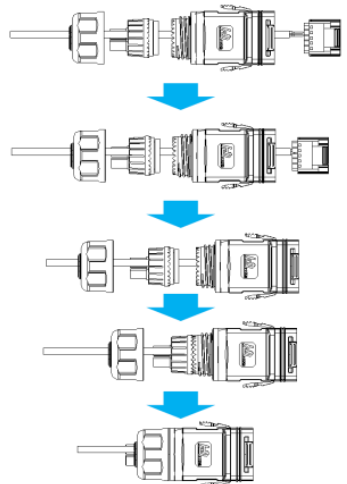
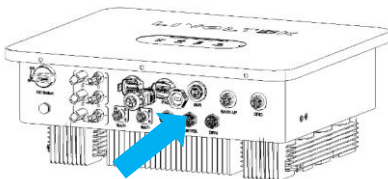



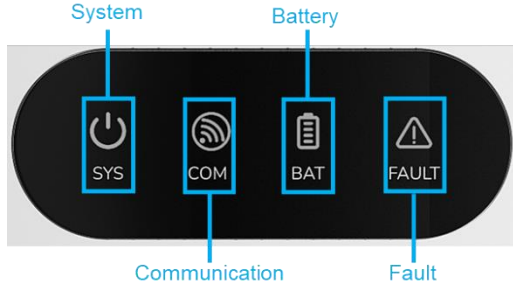

7 System Operation

7.1 LED Display

The inverter operation status can be obtained from observing LED indicator status.



indicator	Color	Status	Description
 SYS	Green	Always on	The inverter is in normal operation (on-grid or off-grid)
		Slow Flash	The inverter is in standby or startup
		Fast Flash	Upgrading
		Always off	System off
 COM	Green	Always on	The meter and dongle are online
		Slow Flash	The meter is online and dongle is offline
		Fast Flash	The meter is offline and dongle is online, system is in upgrading
		Always off	The meter and dongle are both offline
 BAT	Green (Battery symbol)	Always on	Battery connection and BMS communication are both normally
		Slow Flash	Battery is connected normally but BMS communication is abnormal
		Fast Flash	SOC is lower than 10 or battery is in upgrading
		Always off	Battery is not connected
 BAT	Green (capacity symbol)	From bottom to top	Battery is charging
		From top to bottom	Battery is discharging
		No cells on	SOC < 10
		One cell on	Battery is not charging or discharging and $10 \leq \text{SOC} < 25$
		Two cells on	Battery is not charging or discharging and $25 \leq \text{SOC} < 50$
		Three cells on	Battery is not charging or discharging and $50 \leq \text{SOC} < 75$
		All cells on	Battery is not charging or discharging and $75 \leq \text{SOC} \leq 100$
 FAULT	Red	On	System failure
		Flash	EPS port overload
		Off	System is working normally

You can monitor & set data of the inverter through the LIVOLTEK APP. For details about operation, refer to APP User Manual. APP User Manual is available for free from website.

7.2 Start-up Procedures

Check the following items before starting the inverter:

- The country marked on the packing box is in accordance with the installation site.
- The inverter is correctly and firmly fastened to the mounting bracket on the wall.
- All cables are connected according to chapter 6;
- All unused terminals are properly sealed.
- AC circuit breaker is correctly connected between inverter GRID port & GRID, circuit breaker is disconnected.
- AC circuit breaker is correctly connected between inverter EPS port & critical loads, circuit breaker is disconnected.
- For Li-Ion battery, ensure that the BMS cable has been correctly connected.

If all of the items mentioned above meet the requirements, proceed as follows to start up the inverter for the first time.

Step 1: Power on the Grid

- Connect the AC circuit breaker.

Step 2: Power on the Battery

- Connect the external DC circuit breaker between the inverter and the battery, then power on the battery manually if a battery is equipped.

Step 3: Power on the PV

- Rotate the DC switch to "ON". Wait for a moment and the inverter will start a self-test procedure. **Step 4: Switch on the loads**

- The load parameters should show.

Step 5: Configure the stick logger

- Establish communication connection between the mobile phone and stick logger, then set initial protection parameters. Refer to LIVOLTEK APP Operation Instructions for details.

Step 6: Self-test in accordance with CEI 0-21 (Italy Only)

- The self-test is only required for inverters to be commissioned in Italy. During the self-test, the inverter will consecutively check the reaction times for: overvoltage, under-voltage, maximum frequency and minimum frequency.
- Please use the LIVOLTEK APP to initiate the self-test procedure and get the test results. Refer to "Settings on the APP" for details.

Step 7: Observe the LED indicator

- Observe the LED indicator to ensure that the inverter operates normally.

7.3 Shut down Procedures

For maintenance or other service work, the inverter must be switched off. Proceed as follows to disconnect the inverter from the AC and DC power sources.

Notes: Please strictly follow the following procedure. Otherwise, it will cause lethal voltages or unrecoverable damage to the inverter.

Step1: Turn off the loads;

Step 2: Turn off the PV;

Step 3: Turn off battery;

Step 4: Turn off the main grid switch;

Step 5: Wait for at least 5 minutes after the LED and graphical display black out for the internal circuits to discharge energy;

Step 6: Disconnect all the power cables;

Step 7: Disconnect all the communication cables, Remove the stick logger;

Step 8: Remove the inverter from the wall, also remove the bracket if necessary;

Step 9: Pack the inverter with the original carton, and store it.

8 APP Operation

8.1 Download, Configuration, Registration and Login

8.1.1 Downloading and Installing

My Livoltek is a platform to communicate with your device via a stick logger, you can obtain real-time datum and achieve the remote control of your device.

You can login on our web (link as below) on your computer, also you can scan the QR code to download the APP on your phone.

APP:
Search for **My Livoltek** on
Apple App Store, Google
Play.



**Mobile
Explorer**



 **Google Play**



 **Download on the
App Store**

NOTICE

- The device model in all interfaces is for reference only. Please refer to your actual device model.
- All interfaces below are based on APP version V3.12.4. The specific setting interfaces are subject to your actual APP version.

8.1.2 Configuration

8.1.2.1 General Setting

Before any settings on the APP, you can modify the system language as needed, check and confirm that APP server address is consistent with the address for account registration.

Area	Server Region
For Asia, Latin American, Australia and others	International Server https://www.livoltek-portal.com/
For Europe, Middle East Regions, Africa	EU&MEA Server https://evs.livoltek-portal.com/

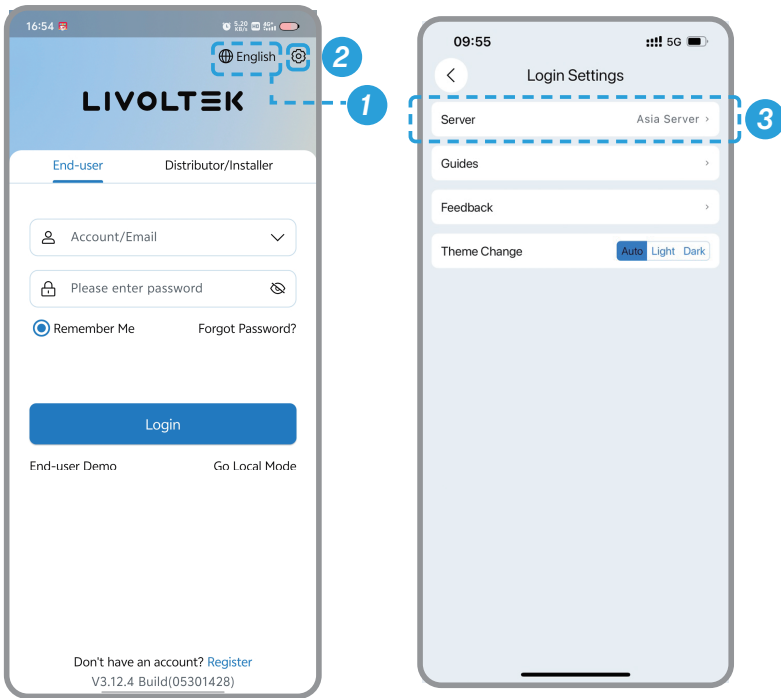

8.1.2.2 Network configuration

Network configuration has two steps: AP connection between your logger and the APP, network configuration among your logger, your router and the cloud.

Network configuration should be completed under APP's local mode on the installation site.

AP Connection between Your Logger and the APP

Step 1: Click **Go Local Mode** → **Wi-Fi Mode** to enter **Local Access** interface.

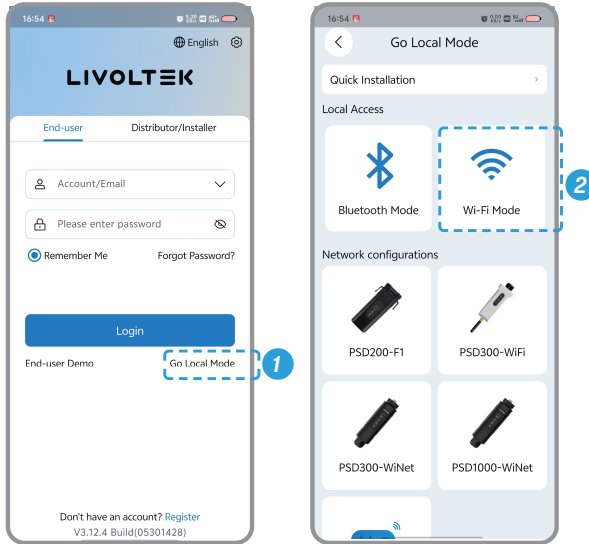

Step 2: Scan the QR code on your stick logger and click **Join** to connect to the logger. Upon successful connection, the APP will jump to the power flow interface under the local mode automatically.

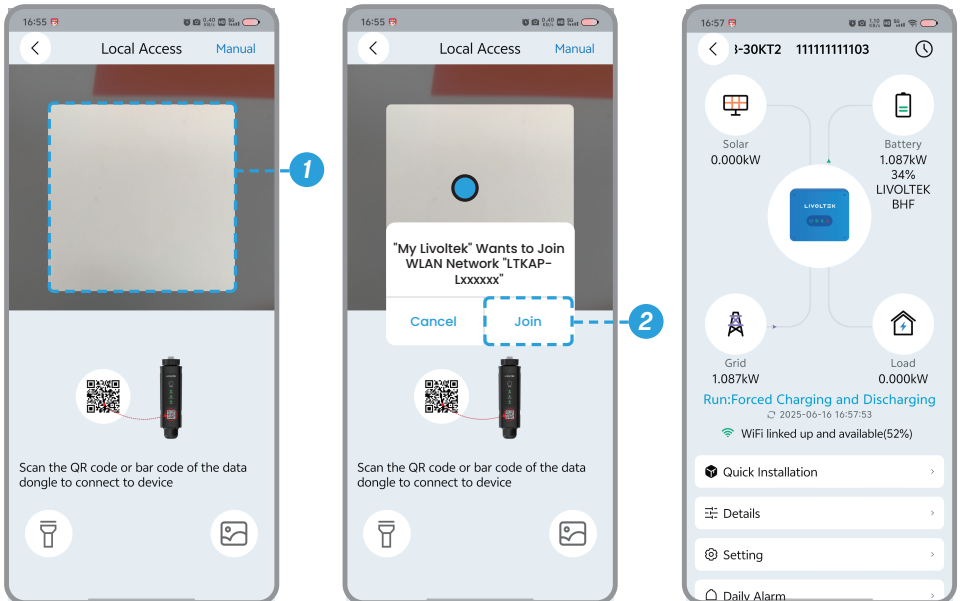

NOTICE

Apart from scanning QR code, you can also connect to the stick logger manually.

Step 1: In Local Access interface, click **Manual** → **Next Step** to the hotspot interface.

Step 2: Connect to your stick logger hotspot in accordance with the last digits of Wi-Fi's SN (LTKAP-XXXXXX). Initial password: admin123456.

Step 3: Set **User Type** as **End-user** in **Local Access** interface and enter the power flow interface.

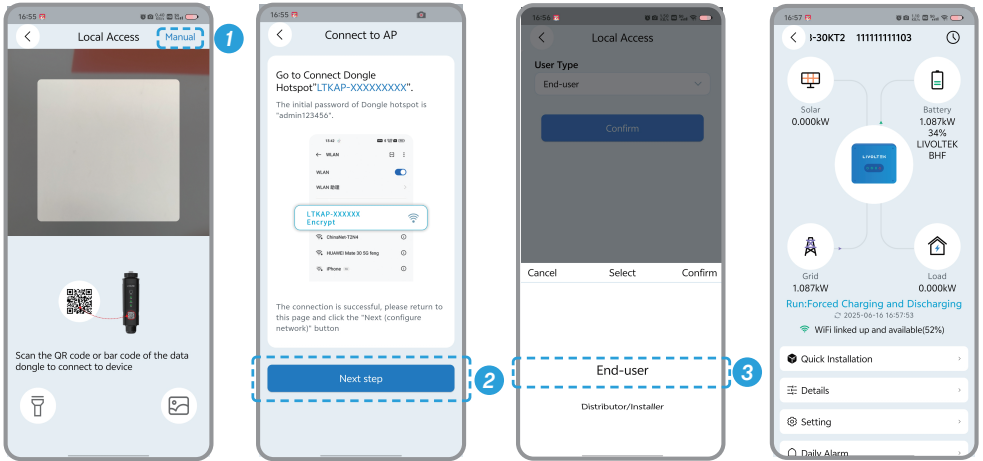

Network Configuration among Your Logger, Router and Cloud

Configure wireless network to make your device online and connected to the monitoring platform. In the power flow interface under local mode, click **Setting** → **Network** → **Server Domain** and set the device server domain.

NOTICE

Please refer to “8.1.2.1 General Setting” and ensure that the two server addresses are consistent.

Area	Server Region
For Asia, Latin American, Australia and others	International Server https://www.livolttek-portal.com/
For Europe, Middle East Regions, Africa	EU&MEA Server https://evs.livolttek-portal.com/

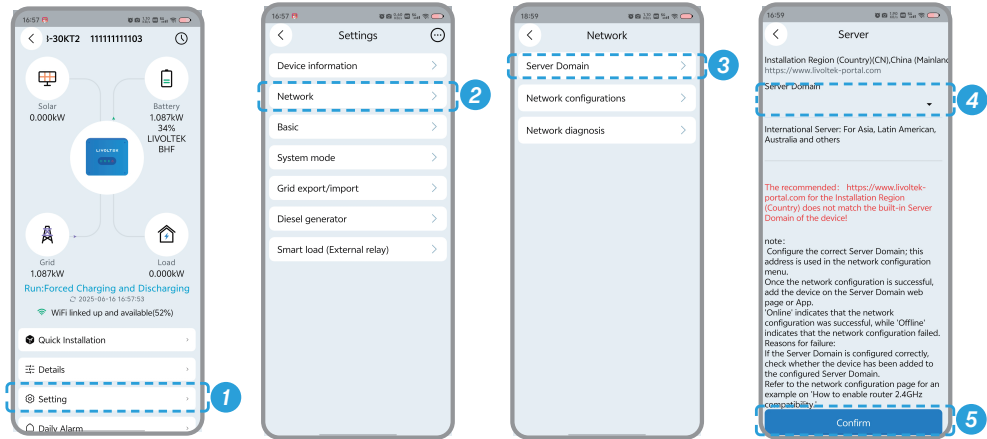

Step 2: Go back to Network interface, click **Network configurations** to enter household Wi-Fi connection interface.

- Enter the Wi-Fi name and password (your household Wi-Fi) and click **Next step**.
- Wait and click **Next step** to complete household Wi-Fi detection.

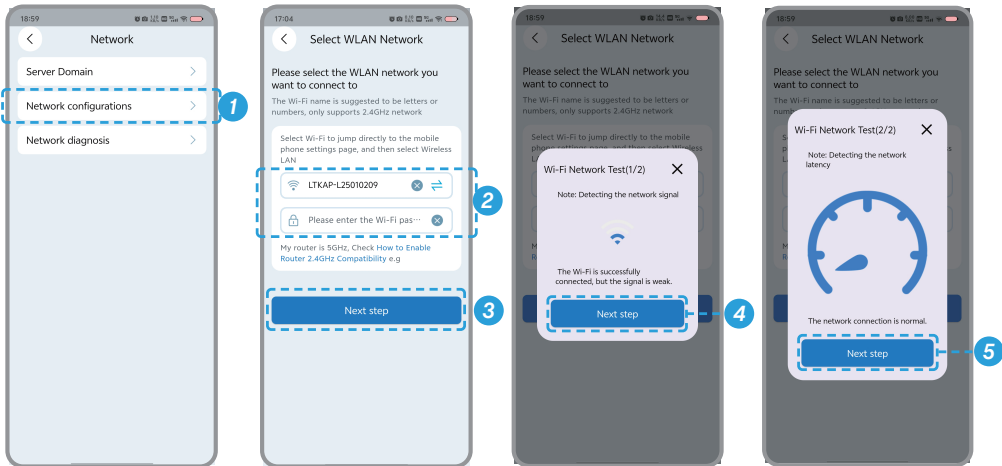

Step 3: After Wi-Fi network test, the interface jumps back to the logger hotspot interface. Click **Next (Configure Network)** → **Start Configuration**, wait until the network configuration process is completed.

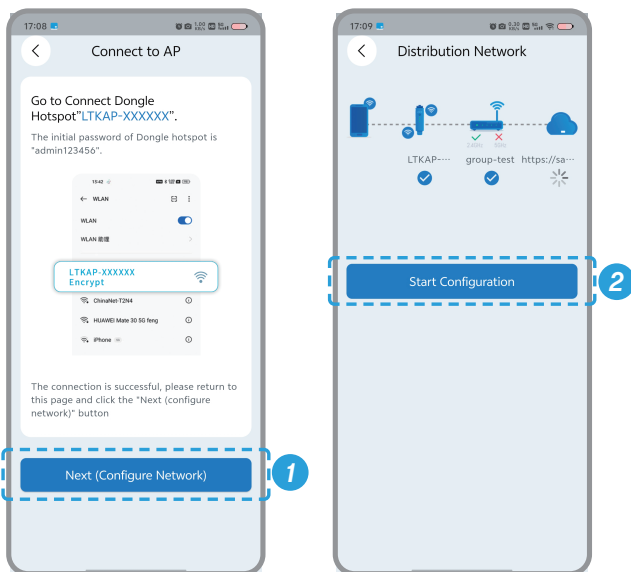

8.1.3 Registration, Site Creation and Device Adding

New Account Registration

NOTICE

If you already have an account, skip this section.

- Step 1: Click **Register**.
- Step 2: Select the server for your region.
- Step 3: Click **Tap to create an account** (End-user).
- Step 4: Complete mandatory fields in the **End-user Register** interface and click **Sign Up**.

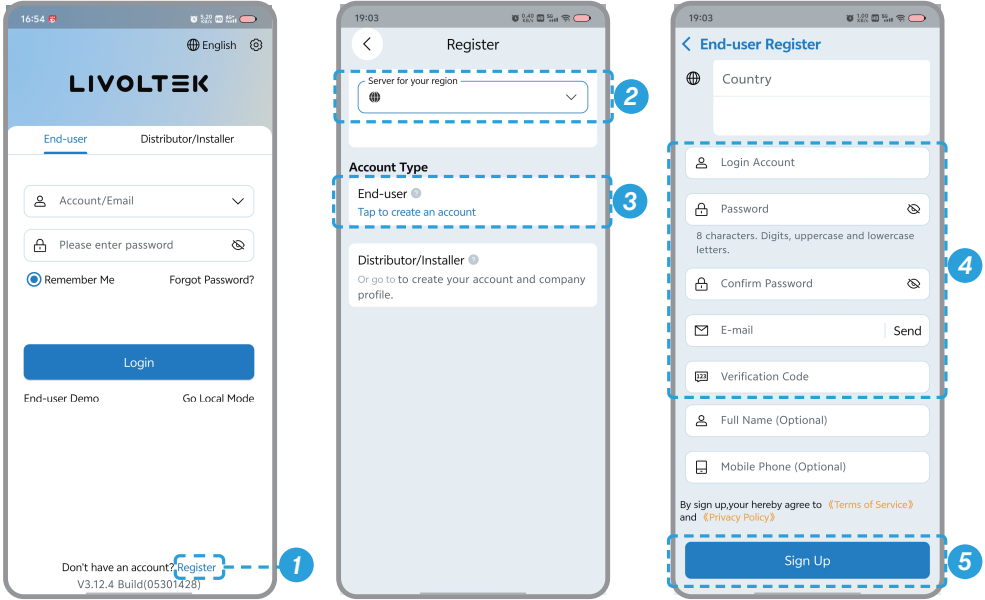

Site Creation

Creating a site to improve the device management. Users can follow the following steps to create your first site.

Step 1: Click **Create A Site Now**.



Step 2: Fill in your **Site Name**, select **Installer (My Livoltek)**, set **Site Address** and click **Next step**.
Site Address: Map: automatically locate and select the address; **Manual:** fill in the address manually.

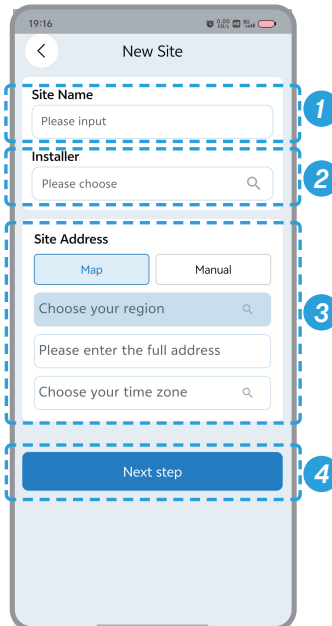

Step 3: Select a **System Type** and **Grid-tied Type** and fill in PV Capacity for your site. Refer to the table below for details. And click **Next step**.

System Type	Description
Residential solar only	For an on-grid inverter
Residential solar energy storage (ess)	For a hybrid inverter
Residential EV Charger	For an EV charger
Residential EV Charger with solar ess	For integrated PV storage and charging machine
C&I ESS	For a comercial and industrial inverter

Grid-tied Type	Description
100% feed-in	Whole energy generated by solar system will be exported to the utility grid.
Self-use first	Solar and storage energy will meet the self-consumption first, the surplus energy will be exported to the utility grid.
0% feed-in	Whole solar and storage energy will meet the self-consumption without surplus.
Off-grid	No matter if the inverter support input from grid, there is no grid connection point in the output.

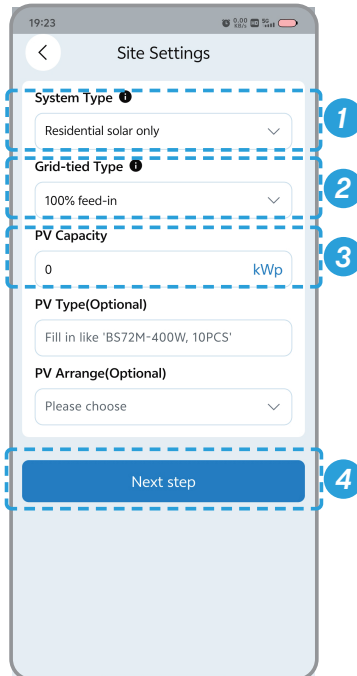

Step 4: Set **Site Tariff Unit**, click **Confirm** and the new site is created.

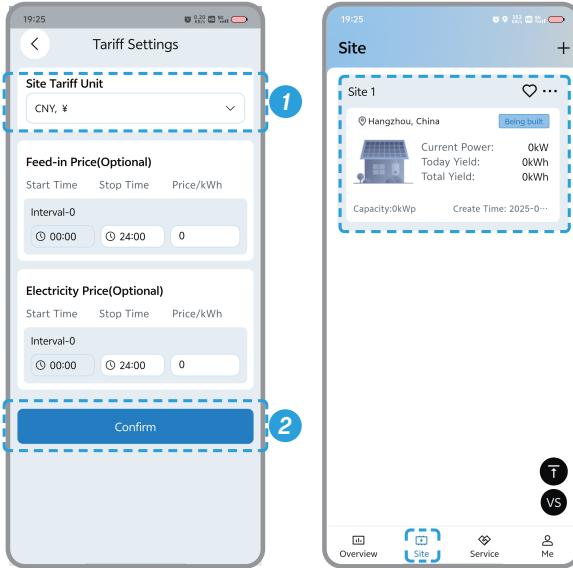

NOTICE

If you already have a site in your account and plan to create a new site, click + on the top right corner of the interface below, follow the above steps to create a new site.

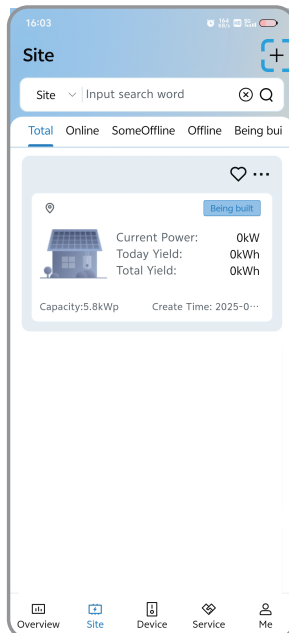

Device Adding

Follow the steps below to add a device (inverter) into your site.

Step 1: Click ... on the top right corner of your site and then click + **Add**.

Step 2: Select **PSD300**, scan the SN bar code or manually enter the SN series number on the nameplate, set your **Device model**, click **Confirm** and your device shall be successfully added.

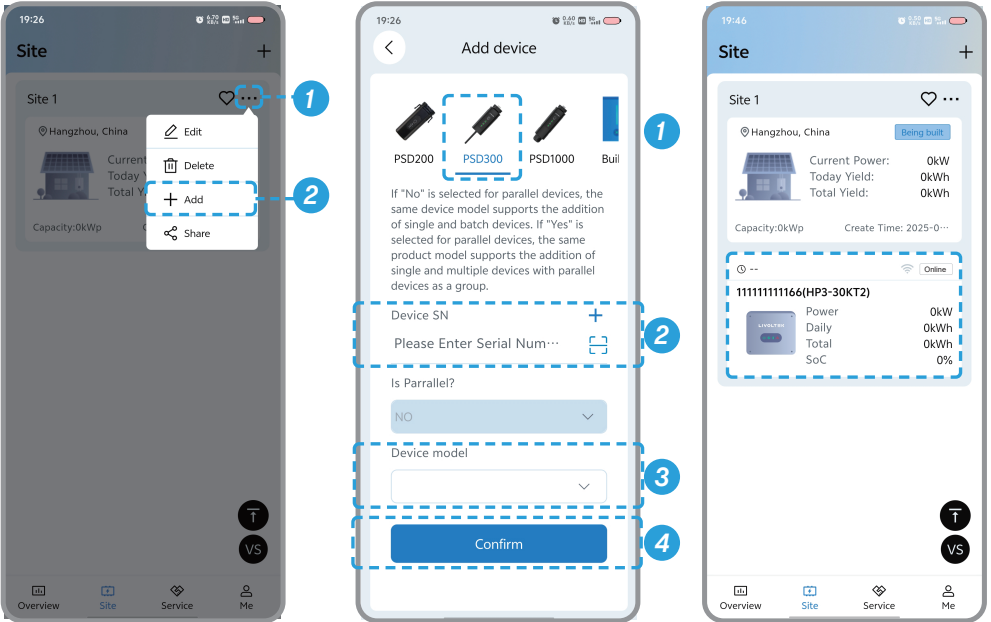

8.2 Function Setting

Scan the QR code below to obtain *Function Setting Guide for Single HP3 Series Inverter* and perform function settings.

NOTICE

For the initial power-on of an inverter, contact our dealer or Livoltek after-sales team to set the work mode, the country, the grid code, feed-in limitation and etc. as needed.



9 Troubleshooting and Maintenance

 WARNING
Before maintaining and commissioning inverter and its peripheral distribution unit switch off all the charged terminals of the inverter, and wait at least 5 minutes after the inverter is powered off.

9.1 Troubleshooting

When the inverter has an exception, its basic common warning and exception handling methods are shown in the table below.

Alarm Number	Alarm Name	Possible causes	Suggestion
1,2,13,14	Grid Overvoltage	Grid voltage higher than the set protection value	Checking the voltage value of the grid. The inverter will be reconnected to the grid after the grid returns to normal.
3,4	Grid Undervoltage	Grid voltage lower than the set protection value	
7,18	Grid Over-frequency	Grid frequency higher than the set protection value	Checking the frequency of the grid. The inverter will be reconnected to the grid after the grid returns to normal.
8	Grid Under-frequency	Grid frequency lower than the set protection value	
9	Grid Down	<ol style="list-style-type: none"> No power from the grid Grid lines or breakers are disconnected 	Checking grid power, circuit wiring, and circuit breaker status.
10	Excess DC component	<ol style="list-style-type: none"> Internal System module abnormality Abnormal system wiring or terminals 	Disconnect the AC test switch and DC side switch, if there is a battery, you need to disconnect the battery side switch. Wait for 15 minutes, then close the AC and DC switches and restart the system.
11	Leakage current fault	The leakage current is higher than the set protection value	This is usually due to cloudy and rainy days, when the weather becomes better, the fault will disappear; if the weather is normal, you need to check that the AC and DC cables have good impedance to ground;

Alarm Number	Alarm Name	Possible causes	Suggestion
12	Grid anomalies	Inverter self-test before grid-connection, triggered if the grid is abnormal	When the grid returns to normal, the inverter will go into grid connection; if the fault occurs repeatedly, please contact the local power company or Livoltek customer service Centre.
16	Grid voltage imbalanced	Imbalance of voltage in each phase of the grid	Check the voltage difference between the voltages of the phases of the grid.
23	Ground fault	Poor inverter grounding	Check whether the chassis is reliably grounded and whether the insulation of the fire wire to ground is good.
98	High ambient temperature	High internal temperature of the inverter	Check that the temperature around the machine is not too high, that it is not in a ventilated position, that it is not exposed to direct sunlight and that the fan is working properly.
100	Low Insulation Impedance	The insulation impedance of the photovoltaic panel to ground is below the required level	Check the ISO protection value; Inspect the PV cables for ground insulation impedance If the cables are normal and the fault occurs during rainy weather, wait until the weather is clear and check again. If there is a battery, check the battery cables for ground insulation impedance
112	EPS Overload	Load power exceeds inverter power	Remove some loads from the off-grid port or reduce their power;
335	Battery communication	Inverter cannot detect battery communication.	Check if the battery communication line and connections are normal to ensure a reliable connection. Reinstall the battery communication line.
42,43,57,449,450,451	PV reverse polarity	PV reverse polarity	Check whether the positive and negative polarity of the corresponding PV string is incorrect.

Alarm Number	Alarm Name	Possible causes	Suggestion
545-551	Battery Alarm		It may be related to environmental temperature, such as overheating or low temperature, in which case, improving the battery's operating environment is necessary.
577-587	Battery Fault		Related to voltage anomalies, check if the battery cables are connected properly, if there is any reverse connection, loose wire ends, etc.
135 , 161 , 163 , 165 , 167 , 169- 174 , 180- 190 , 192 , 197 , 198 , 353 , 354 , 419 , 424- 429,	System Alarm		The inverter can continue to operate. Investigate if there are any abnormalities in the wiring, terminals, or environmental factors corresponding to the alarm, and carry out the necessary repairs.
68, 69, 99, 229, 262	Relay Fault	1. System internal module abnormality 2. Abnormal system-related wiring or terminals	Wait for the inverter to restart operation. Disconnect the DC and AC switches, battery switch, wait for 15 minutes, then reconnect the power to restart the inverter.
6, 10, 15, 17, 18, 21, 22, 24-30 , 33- 56, 58-143, 257 , 258 , 262 , 265 , 269 , 273 , 277 , 281 , 517, 519	System Fault		Wait for the inverter to restart operation. Disconnect the DC and AC switches, battery switch, wait for 15 minutes, then reconnect the power to restart the inverter.



CAUTION

In the event of any of the above situations and if the alarm or fault persists, please contact your local electricity company or the Livoltek Customer Service Centre.

9.2 Routine Maintenance

To ensure that the inverter can operate properly for a long term, you are advised to perform routine maintenance on it as described in this chapter.

 CAUTION
<p>Risk of inverter damage or personal injury due to incorrect service!</p> <ul style="list-style-type: none">• Always keep in mind that the inverter is powered by dual sources: PV strings and utility grid.• Before maintaining and commissioning inverter and its peripheral distribution unit switch off all the charged terminals of the inverter, and wait at least 5 minutes after the inverter is powered off.

Routine Maintenance

Check Item	Method	Period
System clean	Check the temperature and dust of the inverter. Clean the inverter enclosure if necessary.	Once every 6 to 12 months
System running status	Check whether the inverter is not damaged or deformed or can be operated with no abnormal sound.	
Cable entry	Check whether the cable entry is insufficiently sealed, or the gap is excessively large, and reseal the entry when necessary.	
Electrical connection	Check whether all cables are firmly in place. Check whether a cable is damaged, especially the part contacting the metal enclosure.	

9.3 Decommissioning

Perform the following procedures to remove the inverter:

Step 1: Disconnect all cables from the inverter including communications cables, DC input power cables, AC output power cables, and PGND cables.

Step 2: Remove the inverter from the bracket.

Step 3: Remove the bracket.

 WARNING
Before removing DC input connector double check DC input switch, is turned to OFF to avoid inverter damage and personal injury.

9.4 Disposal of the Inverter

The inverter and its packing case are made from environment-friendly materials. If the inverter service life has expired, do NOT discard it with household garbage; dispose the inverter in accordance with local environmental laws and regulations.

10 Technical Data

Notes: (1) Backup output power depends on the battery.

(2) Specifications are subject to change without further notice.

Technical Data	HP3-5KD2	HP3-6KD2	HP3-8KD2	HP3-9.9KD2	HP3-10KD2	HP3-12KD2
PV Input Data						
Recommended Max. PV Input Power (Wp)	10000	12000	16000	20000	20000	24000
Max. PV Input Voltage (V)	1000					
Rated PV Input Voltage (V)	600					
MPPT Operating Voltage Range (V)	150-950					
MPPT Operating Voltage Range (Full-Load) (V)	225-850	270-850	360-850	300-850	300-850	360-850
No. of MPPTs	2			2		
No. of PV Strings per MPPT	1/1			2/1		
Max. PV Input Current (A)	32(16/16)			48(32/16)		
Max. Short Circuit Current (A)	40(20/20)			60(40/20)		
AC Input @Grid						
Max. AC Input Apparent Power (VA)	21000	21000	21000	21000	21000	21000
Rated AC Voltage (V)	3L/N/PE, 220/380; 230/400; 240/415					
Max. AC Input Current (A)	31	31	31	31	31	31
Rated Input Frequency (Hz)	50/60					
AC Output @Grid						
Rated AC Output Power (W)	5000	6000	8000	9900	10000	12000
Max. AC Output Apparent Power (VA)	5000	6000	8000	9900	10000	12000
Rated AC Voltage (V)	3L/N/PE, 220/380; 230/400; 240/415					
Rated Grid Frequency (Hz)	50/60					
Rated Grid Frequency Range (Hz)	45-55/55-65					
Rated AC Output Current (A)	7.6	9.1	12.1	15.1	15.2	18.2
Max. Output Current (A)	7.6	9.1	12.1	15.1	15.2	18.2
THDi, Rated Power (%)	<3					
Output Power Factor	> 0.99 (Adjustable from 0.8 leading to 0.8 lagging)					
EPS Output @Off Grid						
Rated EPS Power (W)	5000	6000	8000	9900	10000	12000

Technical Data	HP3-5KD2	HP3-6KD2	HP3-8KD2	HP3-9.9KD2	HP3-10KD2	HP3-12KD2
EPS Output @Off Grid						
Max. Output Apparent Power (VA)	5500	6600	8800	10900	11000	13200
Rated Output Voltage (V)	3L/N/PE, 220/380; 230/400; 240/415					
Rated Output Frequency (Hz)	50 / 60					
Rated Output Current (A)	7.6	9.1	12.1	15.1	15.2	18.2
THDv (@Liner Load) (%)	< 2					
Switch Time (typical value, ms)	internal switch < 20, external switch < 100					
Battery Data						
Battery Type	Li-ion					
Battery Voltage Range (V)	100-700					
Max. Charge / Discharge Power (kW)	7.5/5	9/6	12/8	14.9/9.9	15/10	15/12
Max. Charge / Discharge Current (A)	50/50					
Charging Strategy for Li-Ion Battery	Self-adaption to BMS					
Communication with BMS	CAN					
Efficiency						
MPPT Efficiency (%)	99.9					
Max. Efficiency (%)	98.2	98.2	98.2	98.2	98.2	98.2
Euro Efficiency (%)	97.2	97.5	97.9	97.9	97.9	97.9
Protection						
DC Reverse Polarity Protection	Integrated					
DC Surge Protection	Integrated					
AC Surge Protection	Integrated					
Output Over Current Protection	Integrated					
Output Short Circuit Protection	Integrated					
Output Over Voltage Protection	Integrated					
Anti-islanding Protection	Integrated					
Insulation Resistor Detection	Integrated					
Residual Current Detection	Integrated					
Ground Fault Monitoring	Integrated					
DC Switch	Integrated					
Leakage Current Protection	Integrated					
AFCI	Optional					

Technical Data	HP3-5KD2	HP3-6KD2	HP3-8KD2	HP3-9.9KD2	HP3-10KD2	HP3-12KD2
General Data						
Dimension (W*H*D)(mm)	540 * 470 * 210					
Weight (kg)	26					
Mounting Method	Wall-mounted					
Ingress Protection	IP65					
Cooling	Natural cooling					
Operating Temperature Range (°C)	-25 to +60 (>45 derating)					
Storage Environments (°C)	-30 to +70					
Max. Operating Altitude (m)	2000					
Noise (dB)	<35					
Relative Humidity (%)	0-100, no condensation					
Cold standby Consumption (W)	<25					
Display	LED & APP					
Communication	RS485, CAN, Wi-Fi, DO, DI					
Topology	Non- isolation					
Security Level	I					
Over voltage category	III(MAINS), II (PV, BATTERY)					

Technical Data	HP3-5KL2	HP3-6KL2
PV Input		
Recommended Max. PV Input Power (W _p)	10000	12000
Max. PV Input Voltage (V)	1000	
Rated PV Input Voltage (V)	350	
MPPT Operating Voltage Range (V)	135-955	
MPPT Operating Voltage Range (Full-Load) (V)	140-700	140-550
No. of MPPTs	2	2
No. of PV Strings per MPPT	2/1	2/1
Max. PV Input Current (A)	48(32/16)	48(32/16)
Max. Short Circuit Current (A)	60(40/20)	60(40/20)
AC Input @Grid		
Max. AC Input Apparent Power (VA)	12000	12000
Rated AC Voltage (V)	3L/N/PE, 120/208; 127/220; 133/230	
Max. AC Input Current (A)	31	31
Rated Input Frequency (Hz)	50/60	
AC Output @Grid		
Rated AC Output Power (W)	5000	6000
Max. AC Output Apparent Power (VA)	5000	6000
Rated AC Voltage (V)	3L/N/PE, 120/208; 127/220; 133/230	
Rated Grid Frequency (Hz)	50/60	
Rated AC Output Current (A)	13.9/13.1/12.6	16.7/15.8/15.1
Max. Output Current (A)	13.9/13.1/12.6	16.7/15.8/15.1
THDi, Rated Power (%)	<3	
Output Power Factor	> 0.99 (Adjustable from 0.8 Leading to 0.8 Lagging)	
EPS Output @Off Grid		
Rated EPS Power (W)	5000	6000
EPS Peak Power (kW) (10s)	10.7	10.7
Rated Output Voltage (V)	3L/N/PE, 120/208; 127/220; 133/230	
Rated Output Frequency (Hz)	50 / 60	
Rated Output Current (A)	13.9/13.1/12.6	16.7/15.8/15.1
THDv (@Liner Load) (%)	< 2	
Switch Time (typical value, ms)	Internal switch < 20, external switch < 100	

Technical Data	HP3-5KL2	HP3-6KL2
Battery Input		
Battery Type	Li-ion	
Battery Voltage Range (V)	100-700	
Max. charge / discharge power (kW)	10/5	12/6
Max. Charge /Discharge Current (A)	50/50	
Charging Strategy for Li-Ion Battery	Self-adaption to BMS	
Communication with BMS	CAN	
Efficiency		
MPPT Efficiency (%)	99.9	
Max. Efficiency (%)	97.9	97.9
Euro Efficiency (%)	97.2	97.3
Protection		
DC Reverse Polarity Protection	Integrated	
DC Surge Protection	Integrated	
AC Surge Protection	Integrated	
Output Over Current Protection	Integrated	
Output Short Circuit Protection	Integrated	
Output Over Voltage Protection	Integrated	
Anti-islanding Protection	Integrated	
Insulation Resistor Detection	Integrated	
Residual Current Detection	Integrated	
Ground Fault Monitoring	Integrated	
DC Switch	Integrated	
Leakage Current Protection	Integrated	
AFCI	Optional	
General Data		
Dimension (W*H*D) (mm)	540 * 470 * 210	
Weight (kg)	25	
Mounting Method	Wall-mounted	
Ingress Protection	IP65	
Cooling	Natural cooling	
Operating Temperature Range (°C)	-25 to +60 (>45 derating)	
Storage Environments (°C)	-30 to +70	

Technical Data	HP3-5KL2	HP3-6KL2
General Data		
Max. Operating Altitude (m)	2000	
Noise (dB)	< 35	
Relative Humidity (%)	0-100, no condensation	
Cold standby Consumption (W)	< 25	
Display	LED & APP	
Communication	RS485, CAN, Wi-Fi, DO, DI	
Topology	Non-isolation	
Security Level	I	
Over voltage category	III(MAINS), II (PV, BATTERY)	

11 Disclaimer

The Hyper series inverters are transported, used and operated under limited condition, such as environmental, electrical etc. **LIVOLTEK** shall not be liable to provide the service, technical support or compensation under conditions listed below, including but not limited to:

- Inverter is damaged or broken by force majeure (such as earthquake, flooding, thunderstorm, lighting, fire hazard, volcanic eruption, war and etc.).
- Inverter's warranty is expired and doesn't buy extended warranty.
- Can't provide the inverter's SN, warranty card or invoice.
- Inverter is damaged by man-made cause.
- Inverter is used or operated against any items in local policy.
- Inverter's installation, configuration, commissioning doesn't follow the requirements mentioned in this manual.
- Inverter is installed, refitted or operated in improper ways mentioned in this manual without authority from LIVOLTEK.
- Inverter is installed, operated under improper environment or electrical condition mentioned in this manual without authority from LIVOLTEK.
- Inverter is changed, updated or disassembled on hardware or software without authority from LIVOLTEK.
- Obtain the communication protocol from other illegal channels.
- Build monitoring, control system without authority from LIVOLTEK.
- LIVOLTEK will keep right to explain all the contents in this user manual.

Contact Information

Netherlands

- 📍 Gruttostraat 9, 5212 VM, 'S-Hertogenbosch, Netherlands
- ☎ +31 (0) 657238010
- ✉ service@livottek.com

Poland

- 📍 Nowa 10, 05-500 Stara Iwiczna, Poland
- ☎ +48 889 822 930
- ✉ service.pl@livottek.com

Italy

- 📍 Via Cavazzana 5, 35123, Padova, Italia
- ☎ +39 800 778 332
- VIP: +39 351 677 3990, +39 392 751 6147
- ✉ service.it@livottek.com

Brazil

- 📍 Av. Guaruba, 585–Distrito Industrial I, Manaus–AM, 69075-080, Brazil
- ☎ +55 11 93338-1338
- ✉ suporte@livottek.com.br

Kenya (East Africa)

- 📍 Sunflag Industrial Park, next to Hilton Garden Inn, Mombasa Road, Nairobi, Kenya.
- ☎ +254 783 884568
- ✉ service.ea@livottek.com

Nigeria (West Africa)

- 📍 9 Baderinwa Alabi Street, Lekki, Lagos
- ✉ service.ng@livottek.com

Colombia

- 📍 Cl. 99#10-08 Piso 7Bogotá, Colombia
- ☎ +57 311 5508402
- ✉ service.co@livottek.com

Vietnam

- 📍 7 Tân Chánh Hiệp 36, Tân Chánh Hiệp, Quận 12, Hồ Chí Minh 70000, Vietnam.

United Kingdom

- 📍 55 Holloway Head, Birmingham B1 1HP, UK
- ☎ +44 7300 839410
- ✉ service.uk@livottek.com

Spain (Iberia)

- 📍 Aeronáutica 6, 28923 Alcorcón (Madrid)
- ☎ +34 671 151 095
- ✉ service.es@livottek.com

Romania

- 📍 DJ691, km 8+775 m, Dreapta, Giarmata City, Timis County, Romania
- ☎ +40742 066 006
- ✉ service.romania@livottek.com

Pakistan

- 📍 Plot Number 13B&14B , 109/M Quaid e Azam Industrial Estate Lahore.
- ☎ +92 370 8435519
- ✉ service.pk@livottek.com

South Africa

- 📍 82 Roan Crescent, Corporate Park North, Midrand, Johannesburg, South Africa
- ☎ +27 79 480 7038
- +27 79 148 8105
- ✉ saservice@livottek.com

Senegal (Northwest Africa)

- 📍 11 rue Vincens x avenue Faidherbe, 5e étage, Dakar, sénégal
- ✉ service.sn@livottek.com

Egypt

- 📍 New Cairo, Cairo, Egypt
- ✉ service.egypt@livottek.com

Dominican Republic

- 📍 Calle Ángel Severo Cabral #19A, Sector Julieta Morales, DISTRITO NACIONAL
- ☎ +18097996550
- ✉ service.dr@livottek.com

Warranty Card Registration

LIVOLTEK

Dear customer, thank you for choosing LIVOLTEK product.

For registering product warranty, please prepare everything ready and register on

<https://www.livoltek.com/registration.html>.

Product Information	
Product Type	
Product S/N	
Installation date	
Installation Company	
Personal Information	
Your name	
Your contact number	
Your Email address	
Your home address	

*Warranties should be registered within 36 months of installation; however, it is recommended that they are registered no more than 6 weeks following the successful installation and commissioning of the Product where possible, thanks for your cooperation.



Contacts

Hangzhou LIVOLTEK Power Co., Ltd

Address: 1418-35 Moganshan Road, Hangzhou, 310011, China

Tel: +86-571-28330320

Fax: +86-571-28020357

Email: info@livoltek.com

Web: www.livoltek.com